

OUTDOOR SOFA

MADE FROM 2X6S

This DIY outdoor sofa is made out of pieces of 2x6 that are screwed together with pocket holes.

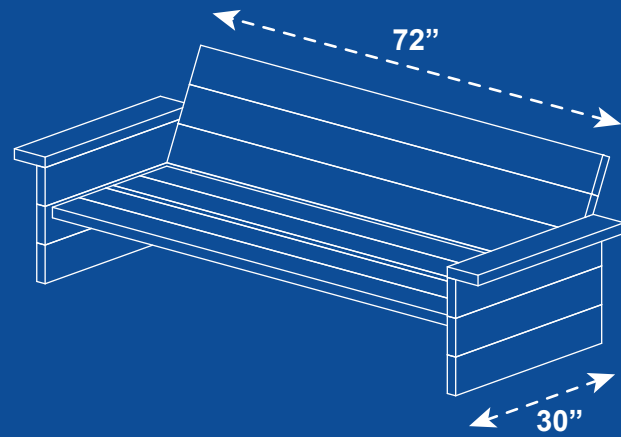

1. CUT THE 2X6S

Cut 8 pieces of 2x6 at a length of 96"

Cut 8 pieces of 2x6 at a length of 30"

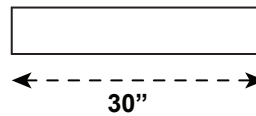
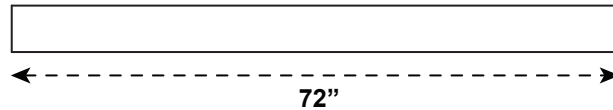

2. ASSEMBLE THE SIDE PANELS

Use pocket holes to connect the pieces. I placed the holes on the inside or under side of the pieces so that they would be less visible.

POCKET HOLES WITH COATED DECK SCREWS

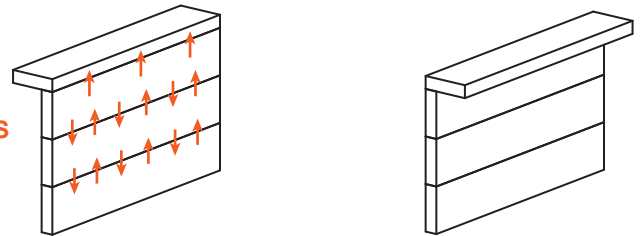

3. ASSEMBLE THE SEAT AND BACK PANELS

Use pocket holes to connect the pieces. I placed the holes on the inside or under side of the pieces so that they would be less visible. The seat panel has a middle piece that is perpendicular to provide strength.

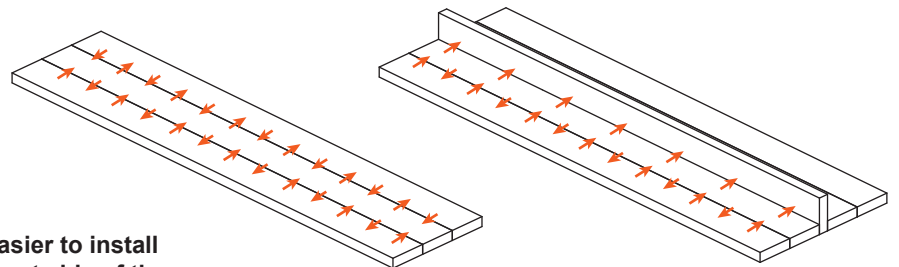

4. ADD THE SEAT PANEL

Placing the side panels upside down makes it easier to install the seat panel. I left 1-1/2" space between the front side of the side panels and the front edge of the seat panel.

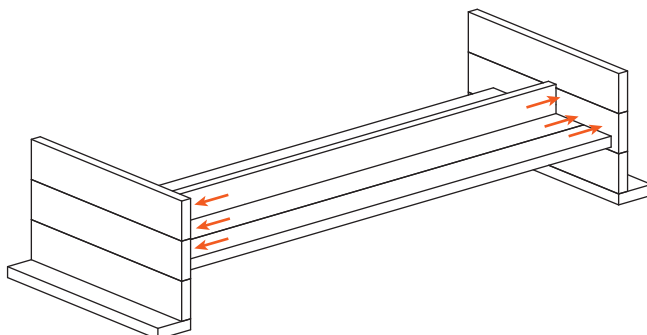

5. ADD THE BACK REST

I left a 1/4" gap between the back rest and seat panel and set the angle to align with the corner of the side panels.

Align back rest to corner of side panels

1/4" gap

1-1/2" from front edge

9"

