

OUTDOOR TABLE MADE FROM 2X6S

This DIY outdoor table is made out of pieces of 2x6 that are screwed together with pocket holes.

There are 2 leg assemblies that are screwed to the underside of the table top.

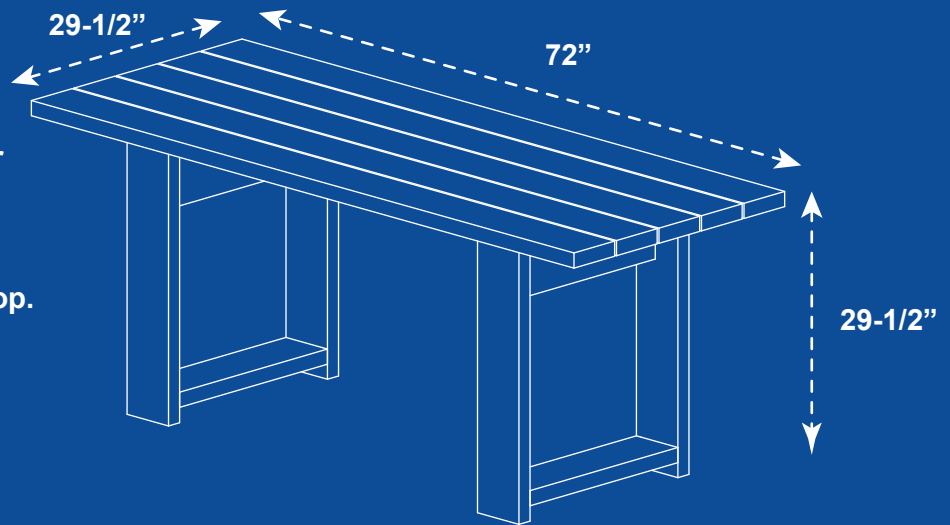

1. CUT AND FASTEN THE TABLE TOP

Cut 5 pieces of 2x6 at a length of 6'

Connect the pieces to make the top using pocket holes every 8 inches on the under side of the table top

I used washers as spacers with the pocket screws going through the center to make gaps for rain water about 1/8" to 1/4" wide

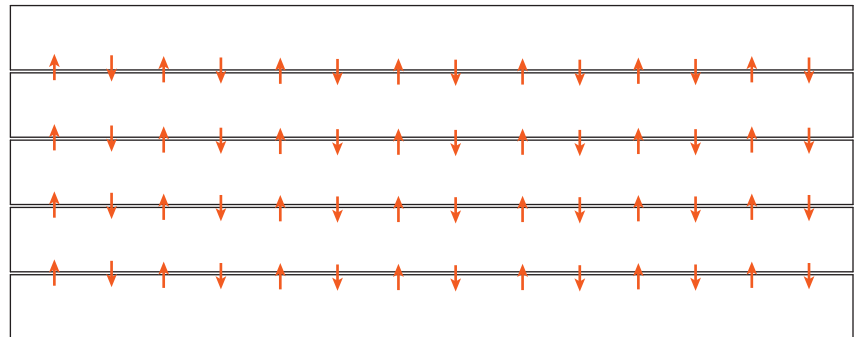

**POCKET HOLES
WITH COATED
DECK SCREWS**

2. ASSEMBLE THE LEGS

Cut 4 legs 28" long and 6 support pieces 20 inches long,

Use pocket holes to connect the pieces. I placed on the holes on the inside or under side of the pieces so that they would be less visible.

Screw through the top cross support on the legs to connect the legs to the table top

