

DIY PAINTING CANVASES

These painting canvases are made from 1-1/2" by 3/4" or 2-1/2" by 3/4" select pine lumber. I used pocket holes to fasten the corners and then reinforced the corners with metal L-brackets for canvases smaller than 36" and with 1/4" or 1/2" plywood triangles to reinforce corners on frames larger than 36". Once the frames are made canvas can be stretched over them and fastened with staples on the back side.

1. CANVASES SMALLER THAN 36"

1-1/2" select pine lumber with 2 pocket holes at each end.

Metal L-brackets to reinforce the corners

POCKET HOLES

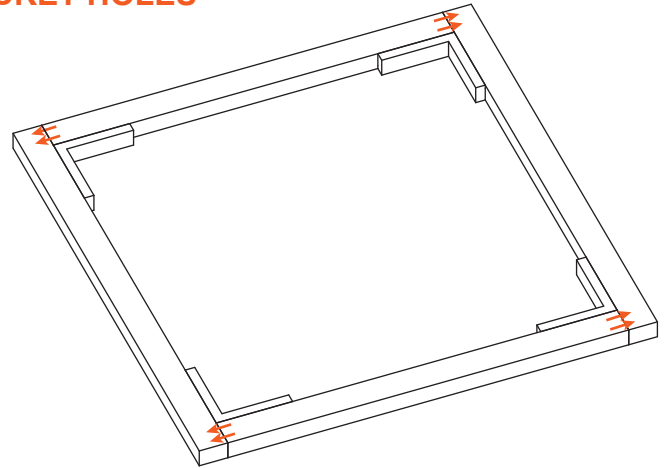

1. CANVASES LARGER THAN 36"

2-1/2" select pine lumber with 2 pocket holes at each end.

8"-10" Plywood triangles 1/4" or 1/2" thick to reinforce the corners

Screw triangles to the back side of the pine frame

A perimeter frame of 1-1/2" by 3/4" select pine makes the frame stronger and gives it a thinner and more premium edge for stretch the canvas

