

Privacy Planter

DIY Plans By:

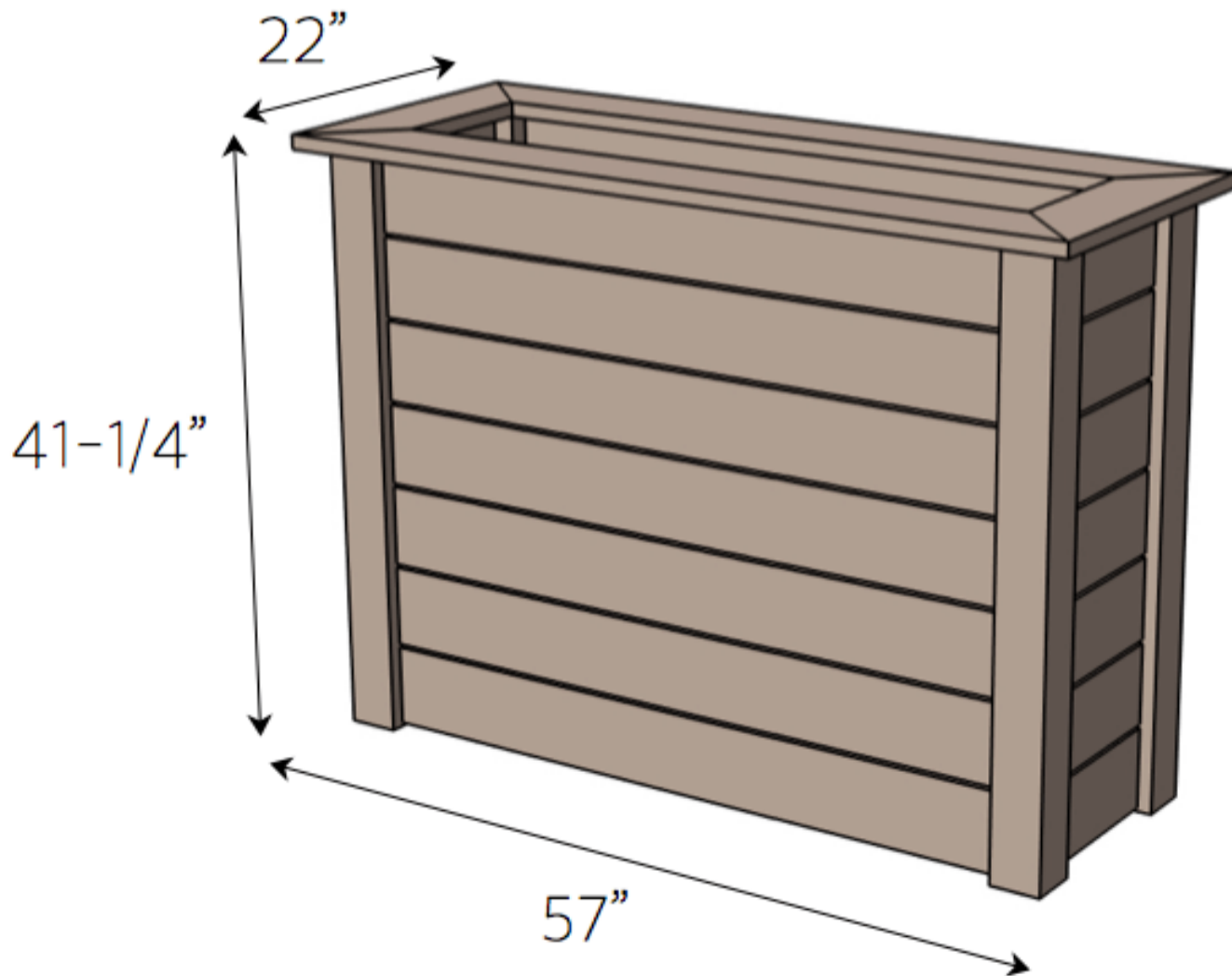

5/4 x 6 x 10'

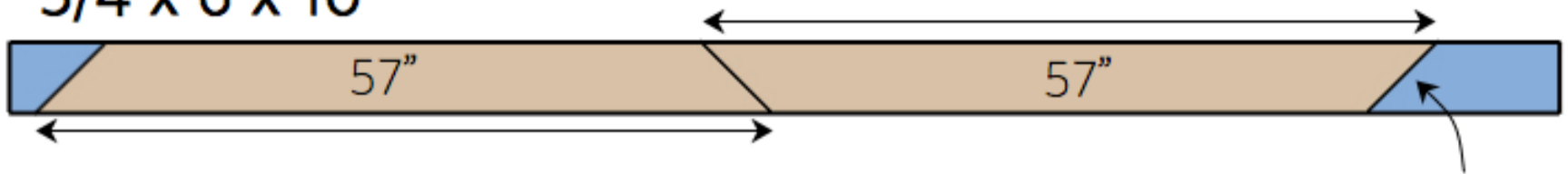

45 deg
(Both Sides)

5/4 x 6 x 8' (Qty 11)

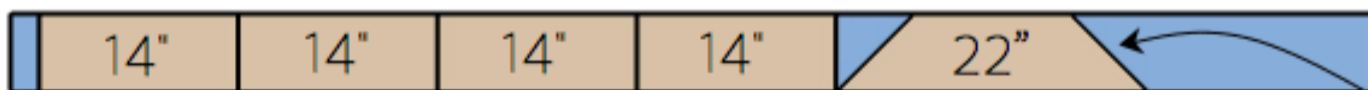
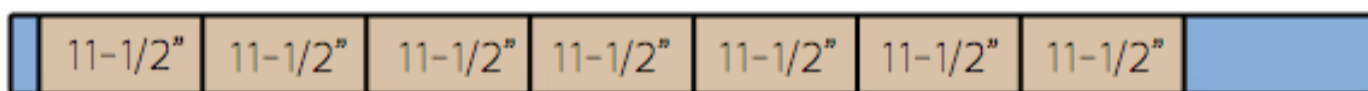
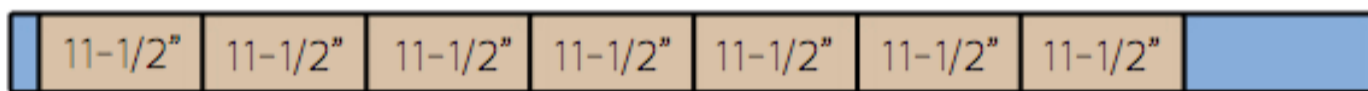

1-1/2" x 1-1/2" Notch (Both Sides)

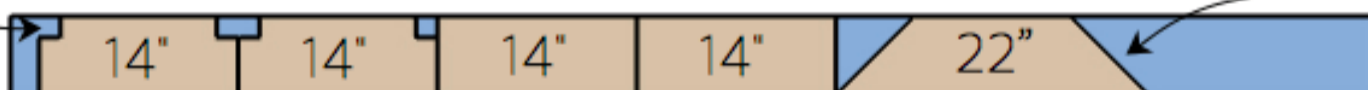

45 deg
(Both Sides)

4 x 4 x 8' (Qty 2)



2 x 4 x 8'



Step 1: Assemble Sides

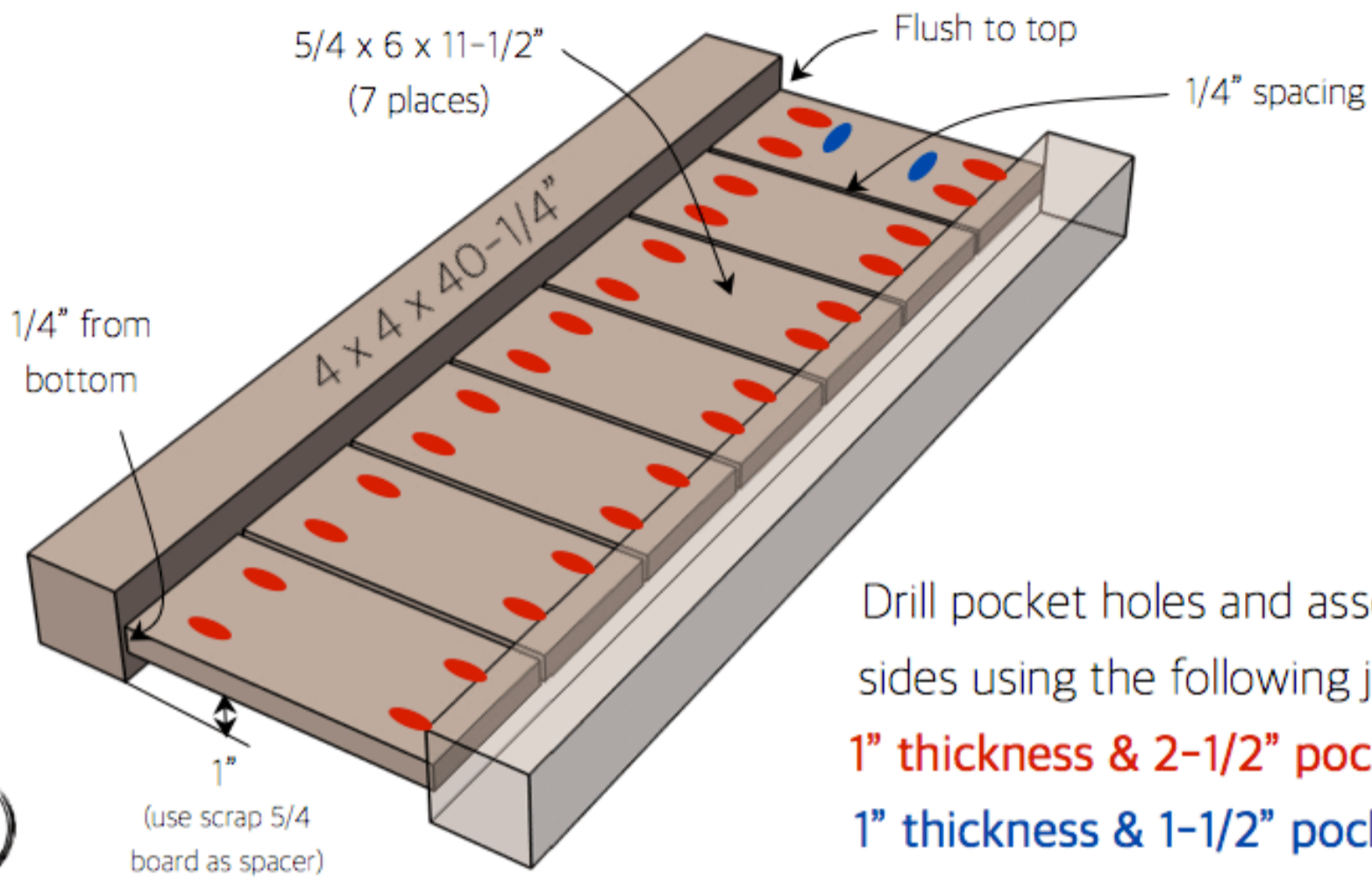

Step 2: Assemble Box

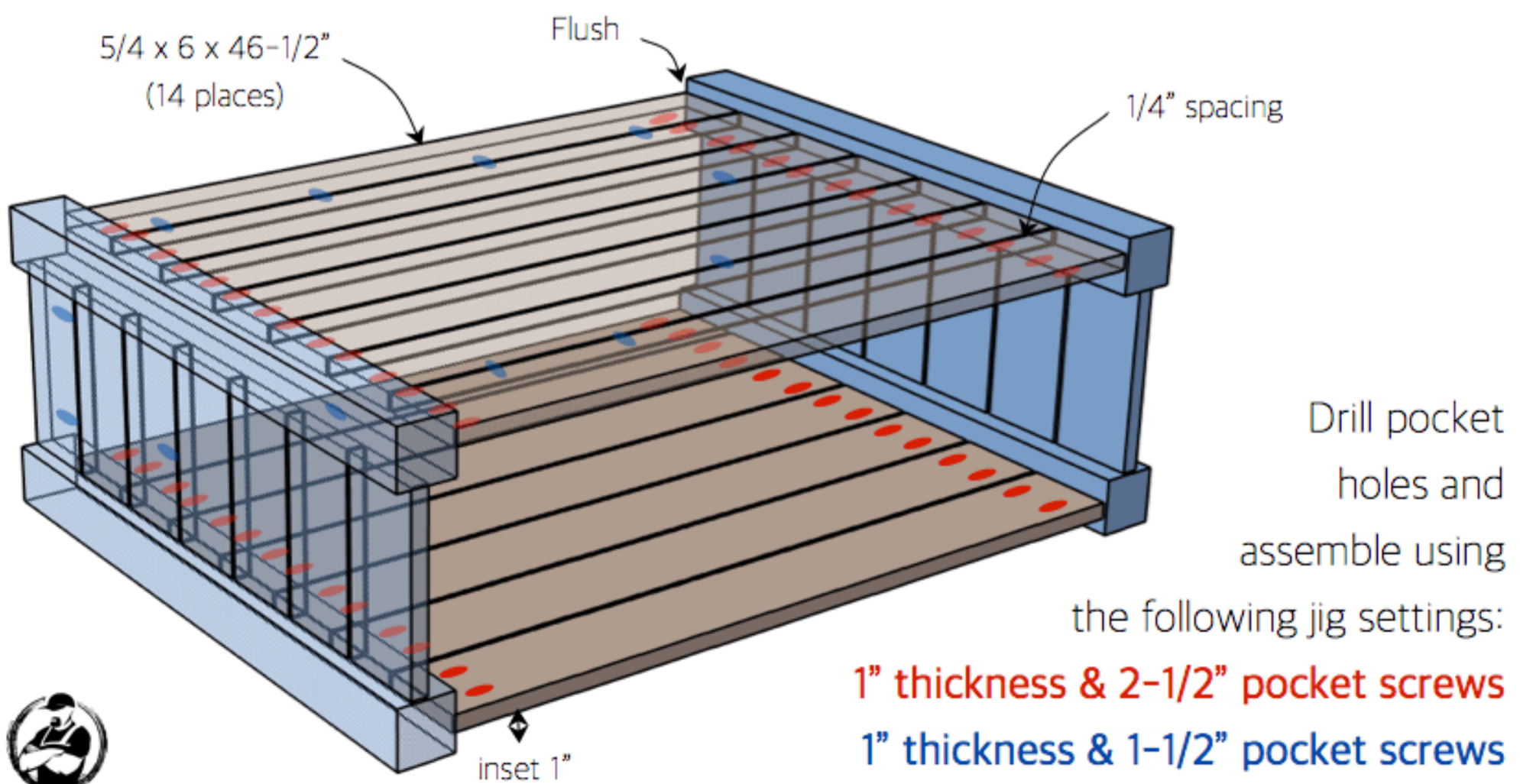

Step 3: Install Supports

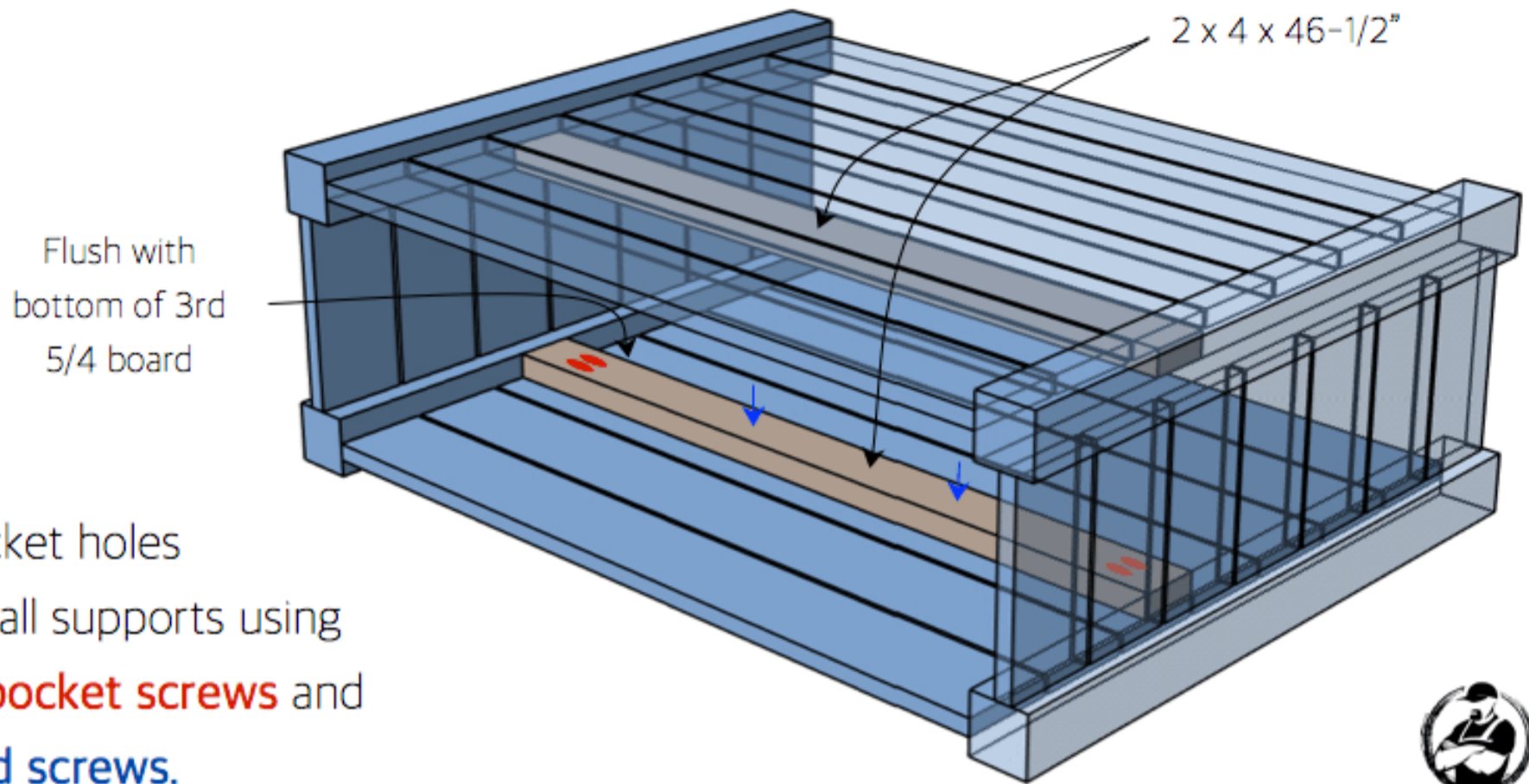

Step 4: Install Planter Base

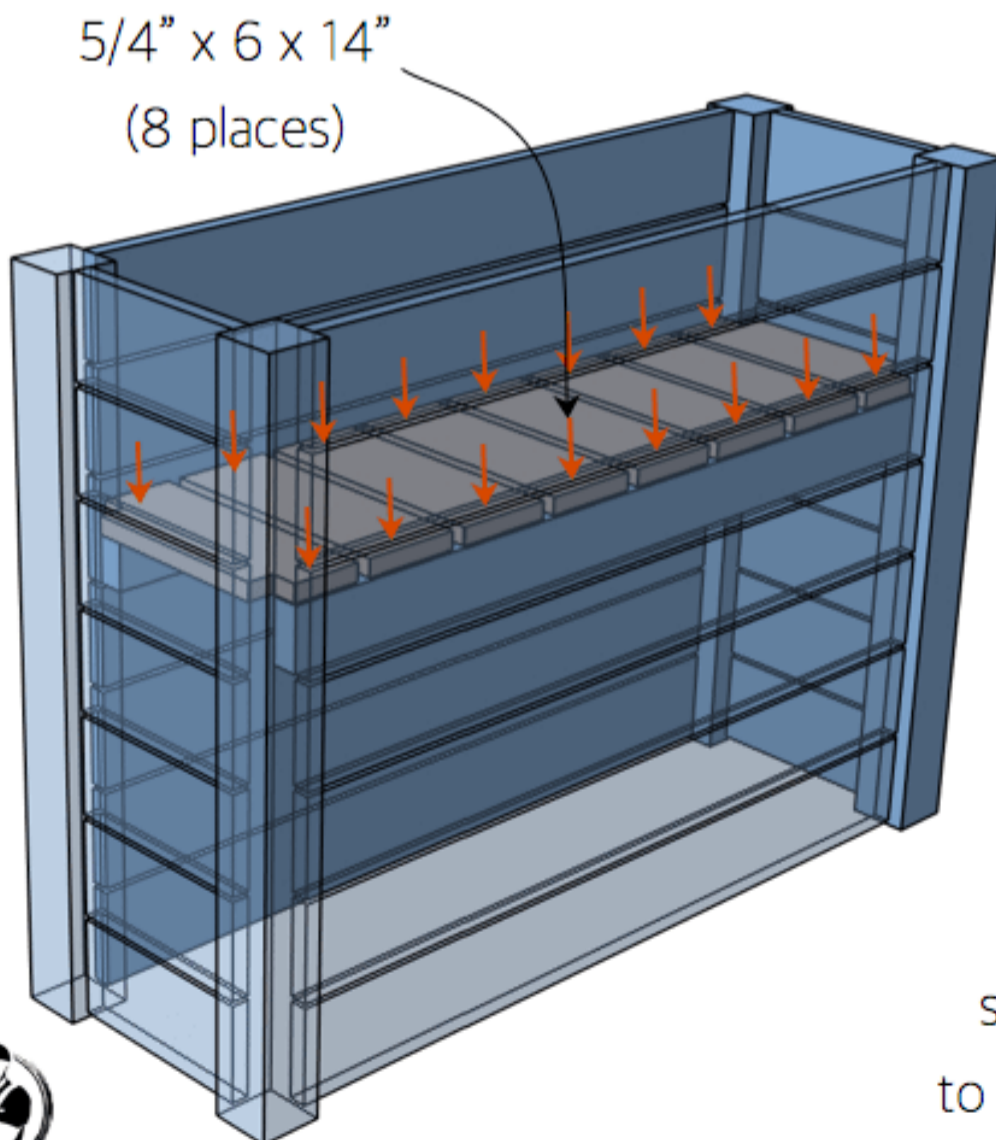

Pre-drill and install planter base using **1-5/8" exterior wood screws**. Space boards approximately 3/4" apart. Staple plastic to the sides and weed barrier to the bottom to retain the soil but allow for drainage.

Step 5: Assemble Cap

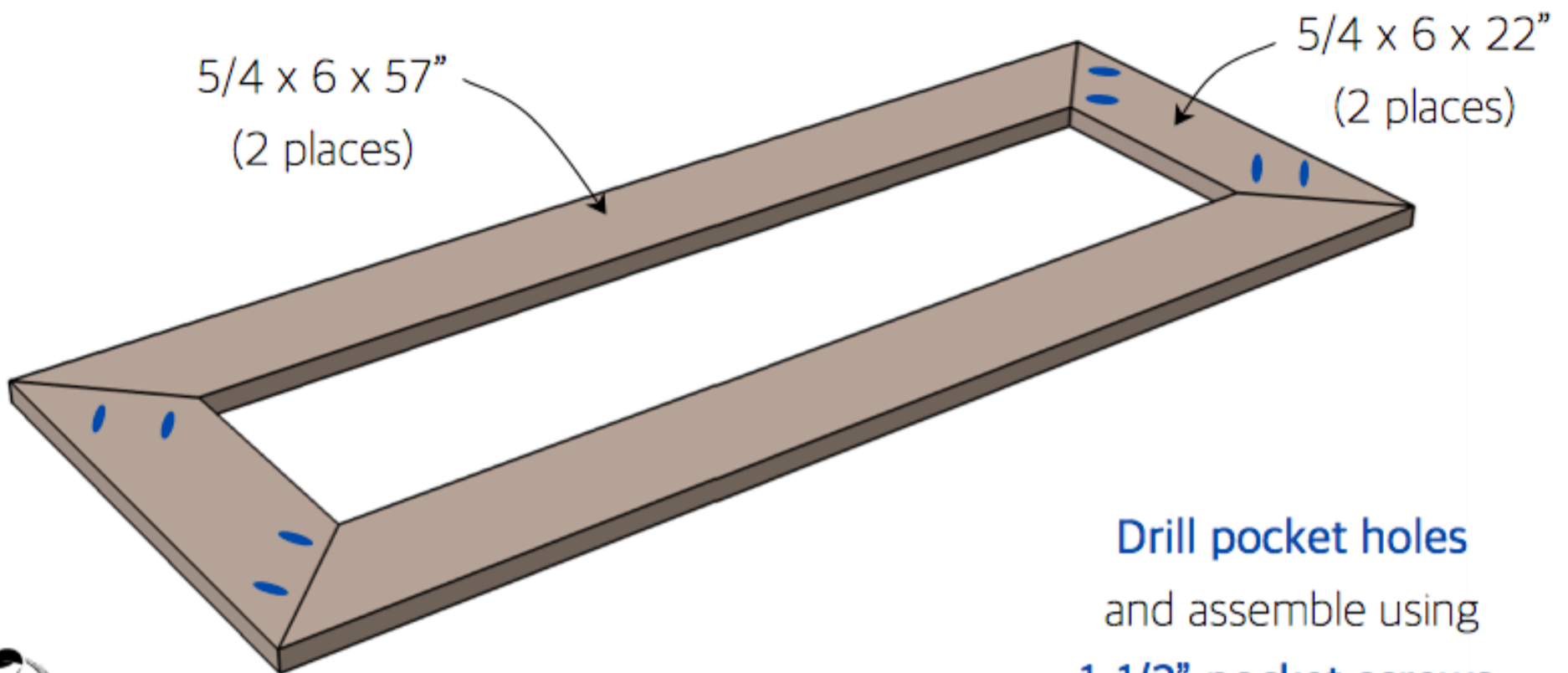

Step 6: Attach Cap

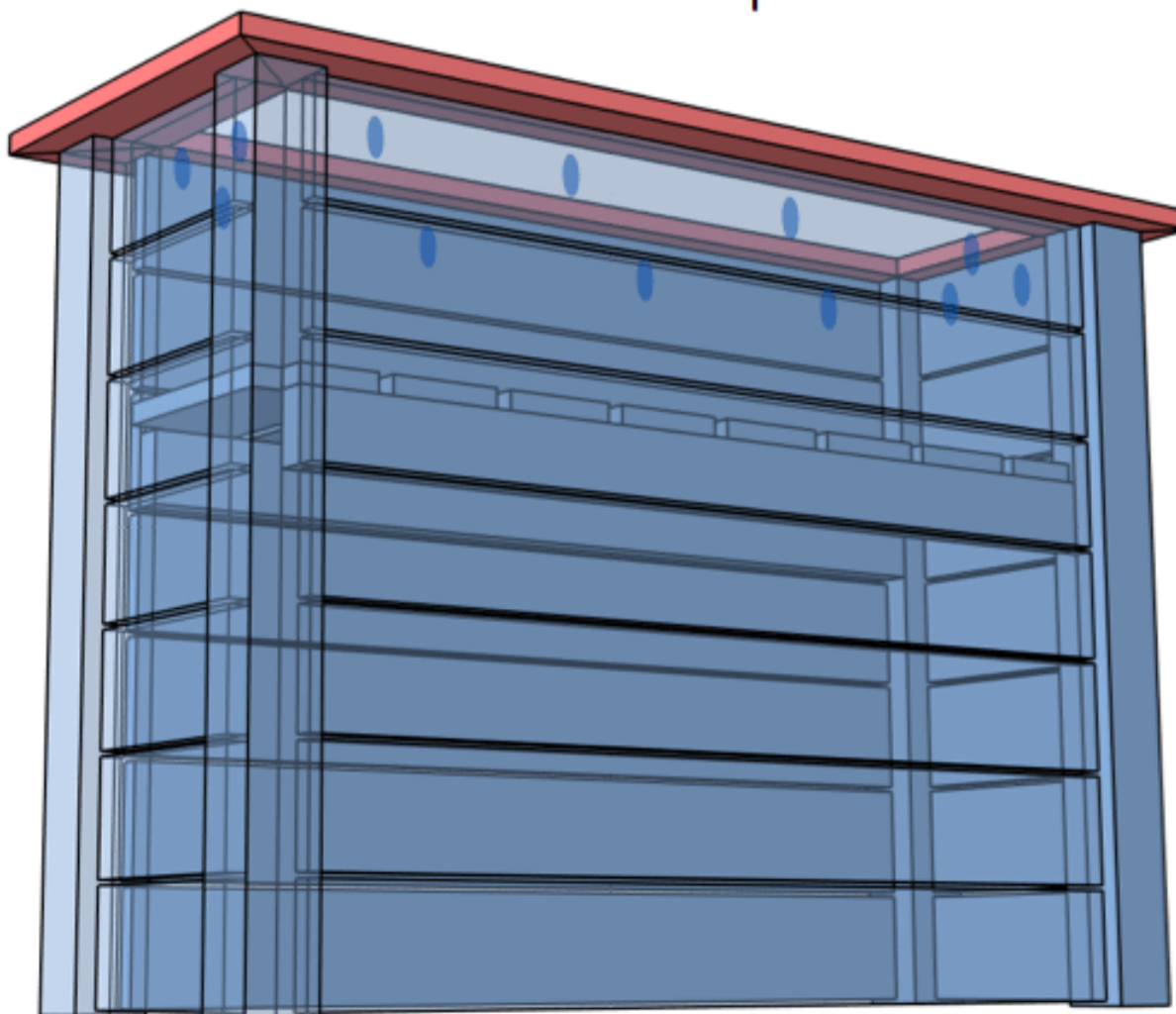

Use **existing**
pocket holes to
attach **cap** with
1-1/2" pocket
screws.

