

# Farmhouse Entryway Bench

By **Woodshop Mike**

Difficulty  
Moderate

---

This bench has a classic farmhouse inspired design fused with black iron pipe that blends with a variety of styles!

This is a great weekend project that will expand your woodworking skills. The use of solid wood, a few angled cuts, and accurate measuring are all part of building this bench.



# Tools

## Kreg Tools



[Kreg® Pocket-Hole Jig 720](#)

## Other Tools

Miter Saw

Square

Table Saw

Tape Measure

Thickness Planer

Clamps

Drill (cordless)

Drill Press

Impact Driver

Sander

Drum Sander

Shop Vacuum

Workbench

# Materials

## Wood Products

**10** Lumber , Rough Sawn , Board Feet

## Hardware & Supplies

**1** 3/4" Black Iron Pipe, 3'

**6** Z-Clips (Screws Usually Included)

**28** 1-1/2" Fine Thread Pocket Hole Screws

**1** Varathane Weathered Wood Accelerator, Quart

**1** Osmo Polyx-Oil, Quart

# Cut List & Parts

- 1 Bench Top , 47" X 12" X 1"
- 4 Leg , 18-13/16" X 2" X 2"
- 2 Apron, Long , 32-29/32" X 1-3/4" X 1"
- 2 Apron, Short , 6" X 1-25/32" X 1"
- 1 Stretcher, Center , 38-13/32" X 2" X 1-1/2"
- 2 Stretcher, Side , 6" X 2-3/8" X 1-1/2"
- 2 3/4" Black Iron Pipe , 17-1/2" Long

**PART 1**  
QTY: 1

NOTE:  
BENCH TOP IS 1" THICK

JASPER, Ga  
www.woodshopmike.com  
mike@woodshopmike.com

---

**PART 3**  
QTY: 2

SEE DETAIL A  
CUT WITH BISCUIT JOINTER SET FOR #20 BISCUITS  
DETAIL A SCALE: 1:3

REV	DATE	BY	DESCRIPTION
A	12/19/18	MP	INITIAL RELEASE

---

**PART 5**  
QTY: 1

PROJECT NAME: METAL & WOOD BENCH  
DRAWING NAME: PARTS 1, 3, & 5

Woodshop Mike, LLC and it's affiliates are not responsible for any damages that may come to persons or properties involved during the creation or use of this project or plans. The use of these plans and construction of this projects is acknowledgement that you as the fabricator assume all liability for proper construction and safe use of the project through all stages.

DWN BY:  
MP

SCALE:

SHT. NO.: 4

Reproduction of this document without the written authorization of Woodshop Mike, LLC is strictly prohibited Copyright 2017, Woodshop Mike, LLC

**PART 2**  
QTY: 4

JASPER, Ga  
www.woodshopmike.com  
mike@woodshopmike.com

**PART 4**  
QTY: 2

**PART 6**  
QTY: 2

PROJECT NAME: METAL & WOOD BENCH  
DRAWING NAME: PARTS 2, 4, & 6

REV	DATE	BY	DESCRIPTION	INITIAL RELEASE
A	12/15/18	MP		

Woodshop Mike, LLC and it's affiliates are not responsible for any damages that may come to persons or properties involved during the creation or use of this project or plans. The use of these plans and construction of this projects is acknowledgement that you as the fabricator assume all liability for proper construction and safe use of the project through all stages.

DWN BY: MP  
SCALE:  
SHT. NO: 5

Reproduction of this document without the written authorization of Woodshop Mike, LLC is strictly prohibited Copyright 2017, Woodshop Mike, LLC

SHT NO.	DESCRIPTION
1	COVER PAGE
2	ASSEMBLY
3	ASSEMBLY SEQUENCE
4	PARTS 1, 3, & 5
5	PARTS 2, 4, & 6

JASPER, Ga  
www.woodshopmike.com  
mike@woodshopmike.com

**METAL & WOOD BENCH**

JASPER, Ga  
www.woodshopmike.com  
mike@woodshopmike.com

PROJECT NAME: METAL & WOOD BENCH  
DRAWING NAME: COVER SHEET

REV	DATE	BY	DESCRIPTION	INITIAL RELEASE
A	12/15/18	MP		

Woodshop Mike, LLC and it's affiliates are not responsible for any damages that may come to persons or properties involved during the creation or use of this project or plans. The use of these plans and construction of this projects is acknowledgement that you as the fabricator assume all liability for proper construction and safe use of the project through all stages.

DWN BY: MP  
SCALE:  
SHT. NO: 1

**DIRECTIONS**

- REVIEW ENTIRE PLAN
- CUT ALL PARTS ON PAGES 4 & 5
- FOLLOW ASSEMBLY SEQUENCE ON PAGE 3  
(For softwoods use 2-1/2" coarse screws. For hardwoods use 1-1/2" fine screws.)
- FINISH AS DESIRED

MATERIALS	
ITEM	QTY
LUMBER	10 BOARD FEET
3/4" BLACK IRON PIPE	35'
Z-CLIPS & SCREWS	6
2-1/2" COARSE or 1-1/2" FINE POCKET HOLE SCREWS	28
FINISH OF CHOICE	

ITEMNO	DESCRIPTION	QTY
1	BENCH TOP	1
2	LEG	4
3	APRON, LONG	2
4	APRON, SHORT	2
5	STRETCHER, CENTER	1
6	STRETCHER, SIDE	2
7	3/4 BLACK IRON PIPE, 17-1/2" LONG	2

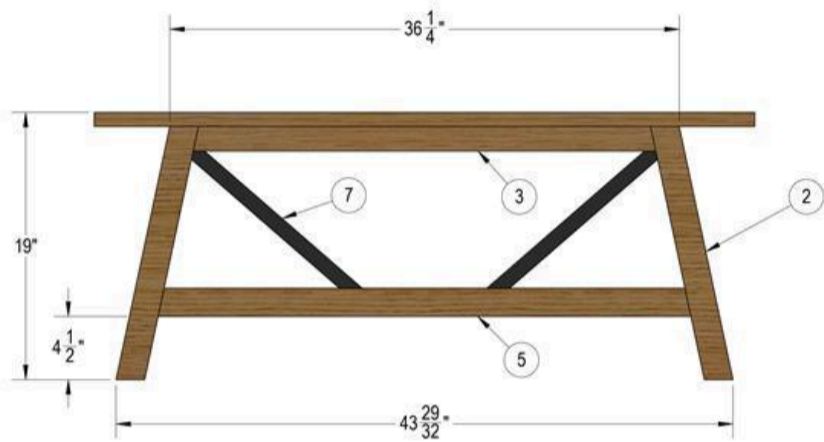
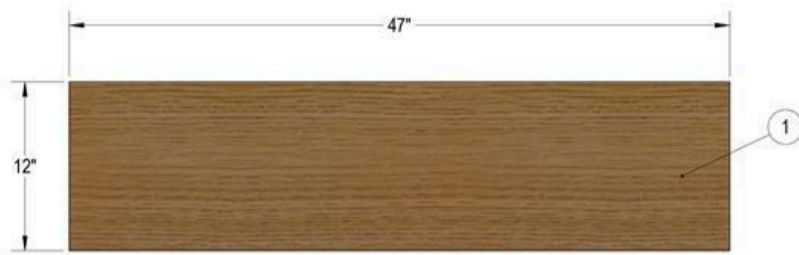

PROJECT NAME: METAL & WOOD BENCH  
DRAWING NAME: ASSEMBLY

REV	DATE	BY	DESCRIPTION
A	12/15/18	MP	INITIAL RELEASE

Woodshop Mike, LLC and it's affiliates are not responsible for any damages that may come to persons or properties involved during the creation or use of this project or plans. The use of these plans and construction of this projects is acknowledgement that you as the fabricator assume all liability for proper construction and safe use of the project through all stages.

DWN BY: MP  
SCALE:  
SHT. NO:

2

Reproduction of this document without the written authorization of Woodshop Mike, LLC is strictly prohibited Copyright 2017, Woodshop Mike, LLC

**STEP 1**



ASSEMBLE PARTS 2 & 4 USING POCKET HOLE SCREWS.  
PART 4 IS RECESSED 1/4" FROM THE OUTSIDE FACE OF PART 2

**STEP 3**

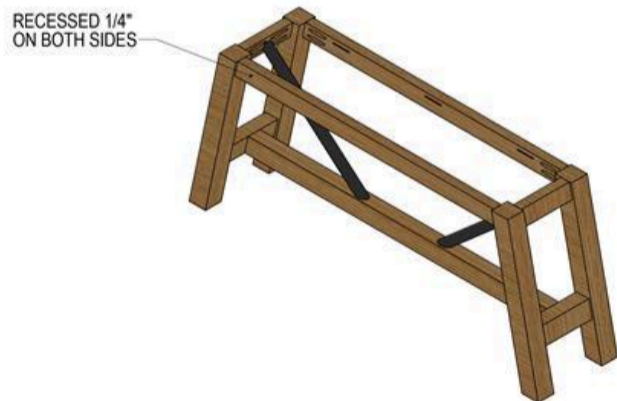

SECURE PART 3 TO PART 2 USING POCKET HOLE SCREWS.  
PART 3 IS RECESSED 1/4" FROM FACE OF LEGS AS IN STEP 1.

**STEP 2**

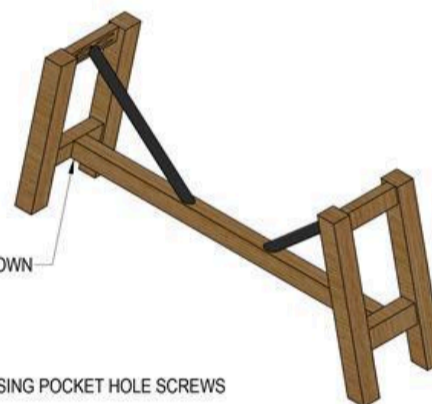

POCKET HOLES FACE DOWN

ASSEMBLE PARTS 5 & 6 USING POCKET HOLE SCREWS  
ADD 3/4" PIPE TO HOLE DRILLED IN PARTS 4 & 5  
SECURE PART 6 TO PART 2 USING POCKET HOLE SCREWS

**STEP 4**



ATTACH BENCH TOP USING Z-CLIPS



PROJECT NAME: METAL & WOOD BENCH  
DRAWING NAME: ASSEMBLY SEQUENCE

REV	DATE	BY	DESCRIPTION
A	12/15/18	MP	INITIAL RELEASE

Woodshop Mike, LLC and it's affiliates are not responsible for any damages that may come to persons or properties involved during the creation or use of this project or plans. The use of these plans and construction of this projects is acknowledgement that you as the fabricator assume all liability for proper construction and safe use of the project through all stages.

DWN BY: MP  
SCALE:  
SHT. NO:

3

Reproduction of this document without the written authorization of Woodshop Mike, LLC is strictly prohibited Copyright 2017, Woodshop Mike, LLC

# Directions

---

1

## Rough Cuts

I start off by picking out my boards and chopping everything to rough length on the miter saw.

Next, I head over to the table saw and rip my boards to their rough widths, which is about 1/4" wider than the final size needed.

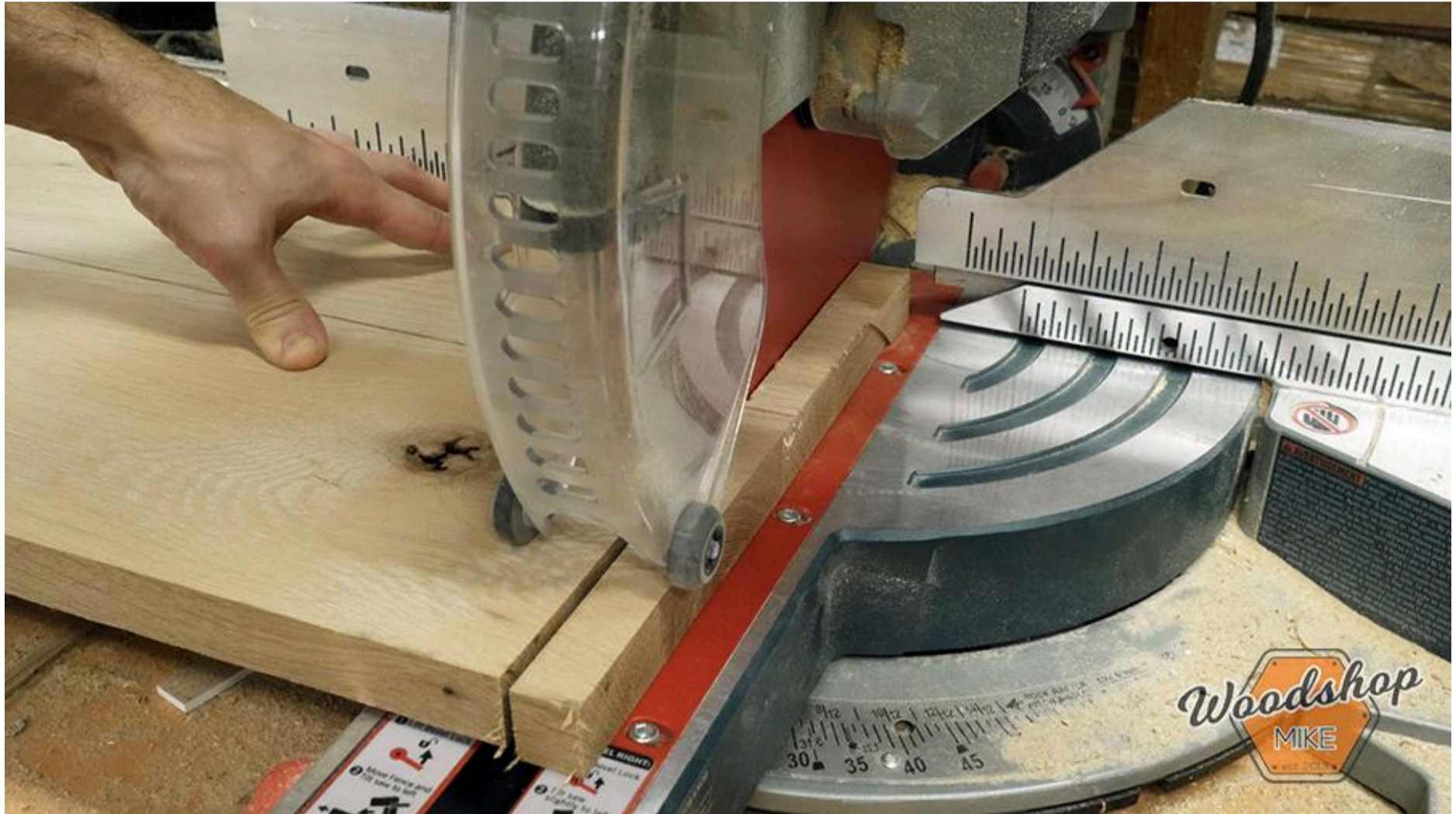

2

## Intro

Much of the process I describe will be based on working with rough-sawn lumber. However, this bench can certainly be built from dimensional lumber available from your local big box home center.

If you're using dimensional lumber like 2X4s, 1X12s, and 2X4s, just skim over some of the milling operation details!

---

### 3

#### Make Legs

Since I don't have any 8/4 stock to make the legs from, I'll have to glue up a few boards first.

I start by running my stock through the planer until I have at least one surface that is flat.

With all of my boards for the legs planed, I grab my clamps and get started gluing them up. Be sure to "mirror" the end grain pattern; this will help deter the piece from warping over time.

After the glue has cured, these pieces are planed just shy of their final dimensions and then run through the drum sander.

The last step is to cut the ends to 12° and set them somewhere safe until assembly.



# 4

## Make Bench Top

The bench top is pretty straight forward. I repeat the basic milling operations again and glue up the necessary boards.

Once the glue is cured, I mill and sand the top to final thickness. I then rip and cross cut the top to it's final size.

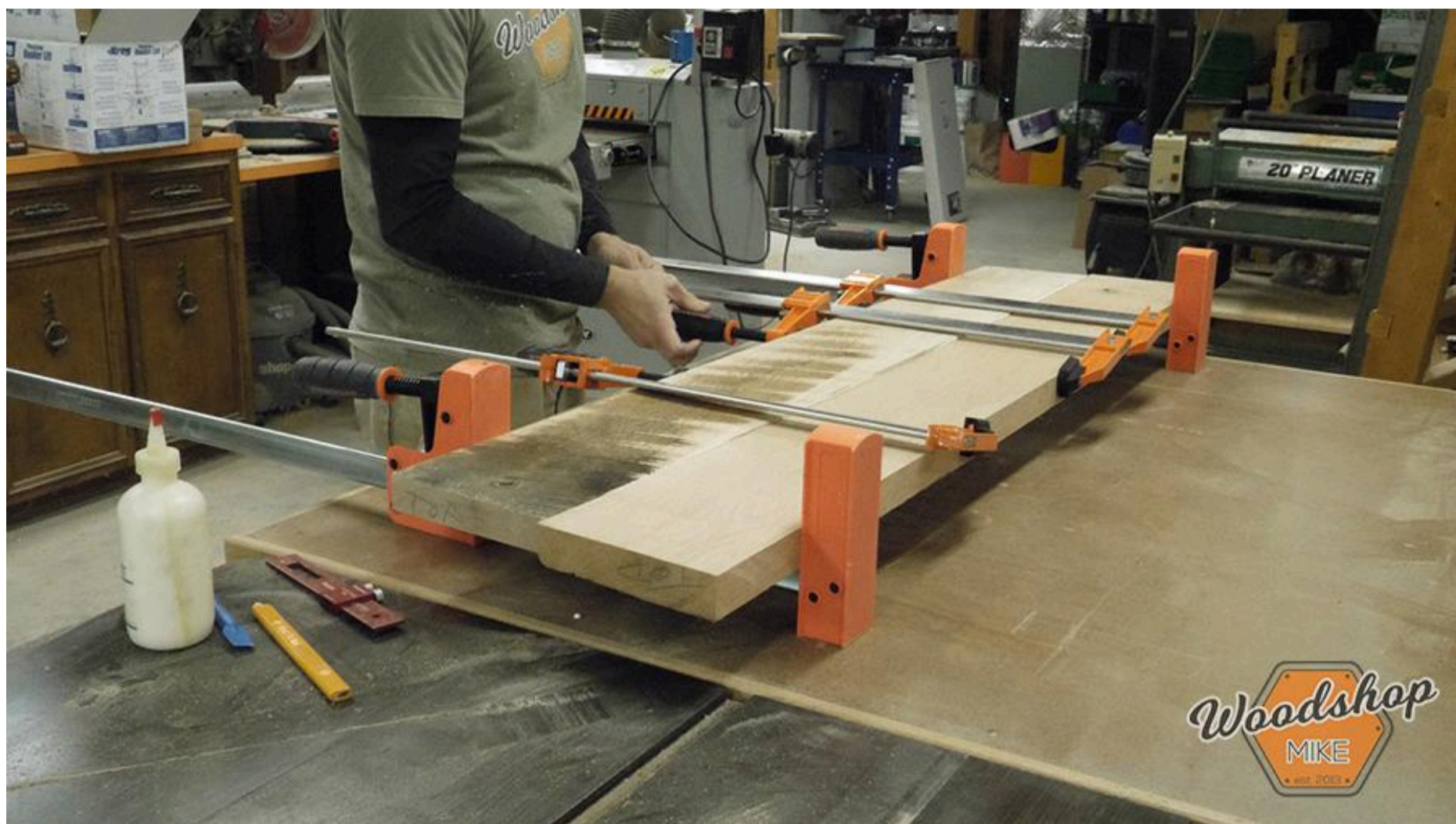



# 5

## Make Aprons

With the long and short aprons milled per the plans, it's time to cut them to length and add pocket holes. Note that the long apron is cut with a 12° angle on each end.

Now is also the best time to cut the slots for the z-clips that will hold the bench top in place. I used my biscuit joiner for this task.

If a biscuit joiner isn't available, you could use a hand router or drill and chisel to make the slots.



## 6

### Make Stretchers

The stretchers are made very similarly to the aprons.

With the items milled to their proper sizes, cut them to the final lengths. Note that the center stretcher has a 12° angle on both ends.

Next, drill the pocket holes as noted in the plans.



# 7

## Drill For Pipe

Now over at the drill press, I set up to drill holes for the 3/4" pipe (O.D. 1.050") to rest in. I use a digital angle finder to dial in the correct angle on my drill press table.

Now, I grab a 1-1/16" Forstner bit and drill holes in the short aprons and center stretcher as shown in the plans.

Be sure to hold the pieces securely with clamps during this operation.

NOTE: If you prefer the look of 1/2" pipe (O.D. .840") use a 7/8" Forstner bit instead.

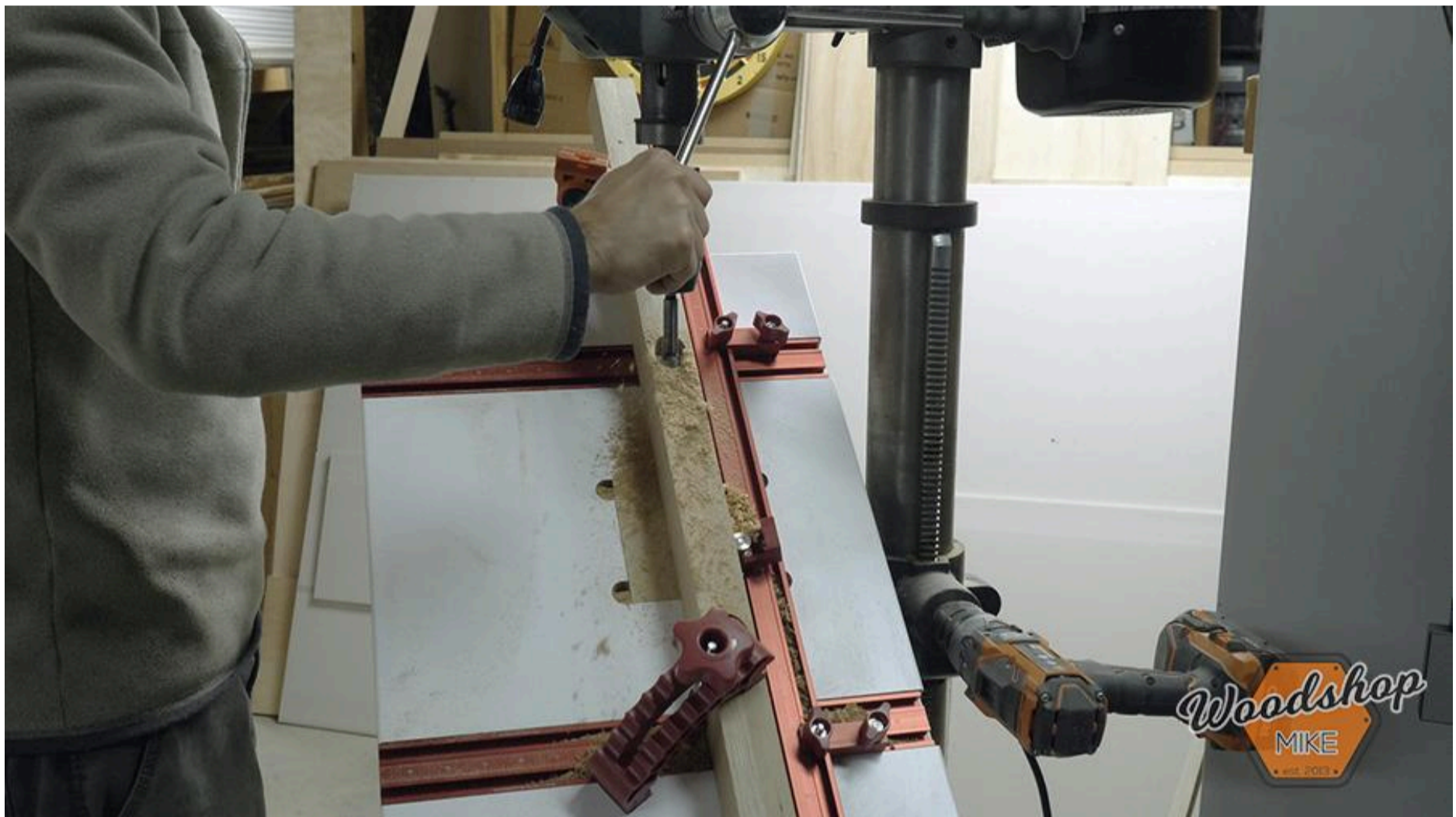

## 8

### Base Assembly 1

To build the left and right sets of legs, I start off by laying out two legs on the bench, making sure that the angles on each end are pointing the same direction as shown in the plans.

Next, I place some 1/4 plywood between the legs and place one short apron and one side stretcher between the legs.

I now screw the short apron into place using 1-1/2" fine thread screws.

Repeat above procedure for the other legs.

NOTE: If using softwoods, use coarse thread screws.



**9****Base Assembly 2**

Next, I secured the center stretcher and short stretchers together using 1-1/2" pocket hole screws.

Then I put one end of each pipe into the holes drilled into each short apron and the center stretcher.

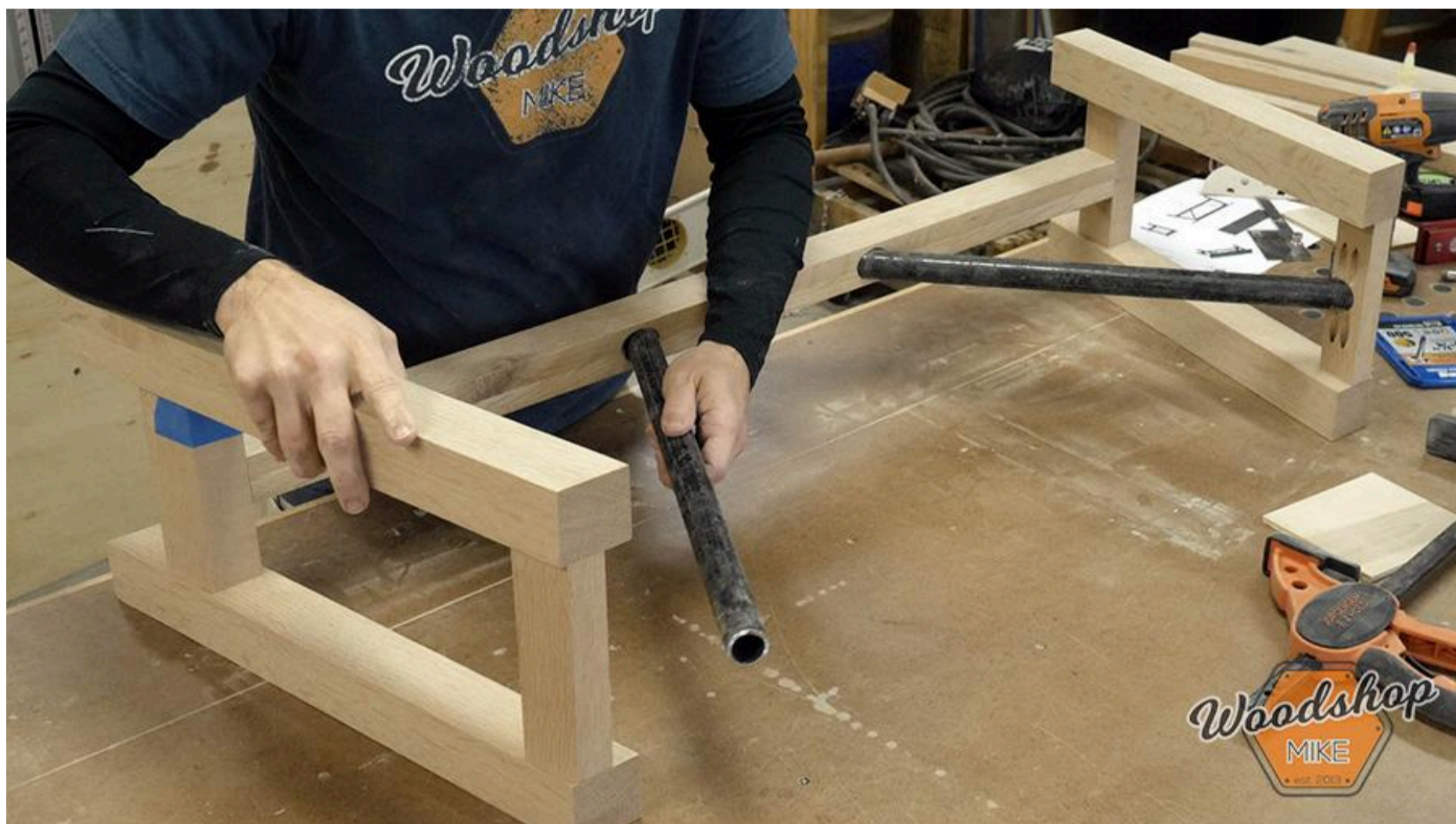

**10****Base Assembly 3**

Now I simply position the stretcher as shown in the plans and secure it with 1-1/2" pocket hole screws.

The space here is pretty tight, so you'll need either a very long square drive bit, a very small impact driver, or a 1/4" socket wrench to drive the screws in.



11

### Attach Top

I now place the bench top face down on my work surface and center the base on the bench top.

I locate z-clips into each of the biscuit slots and secure them with the provided screws.

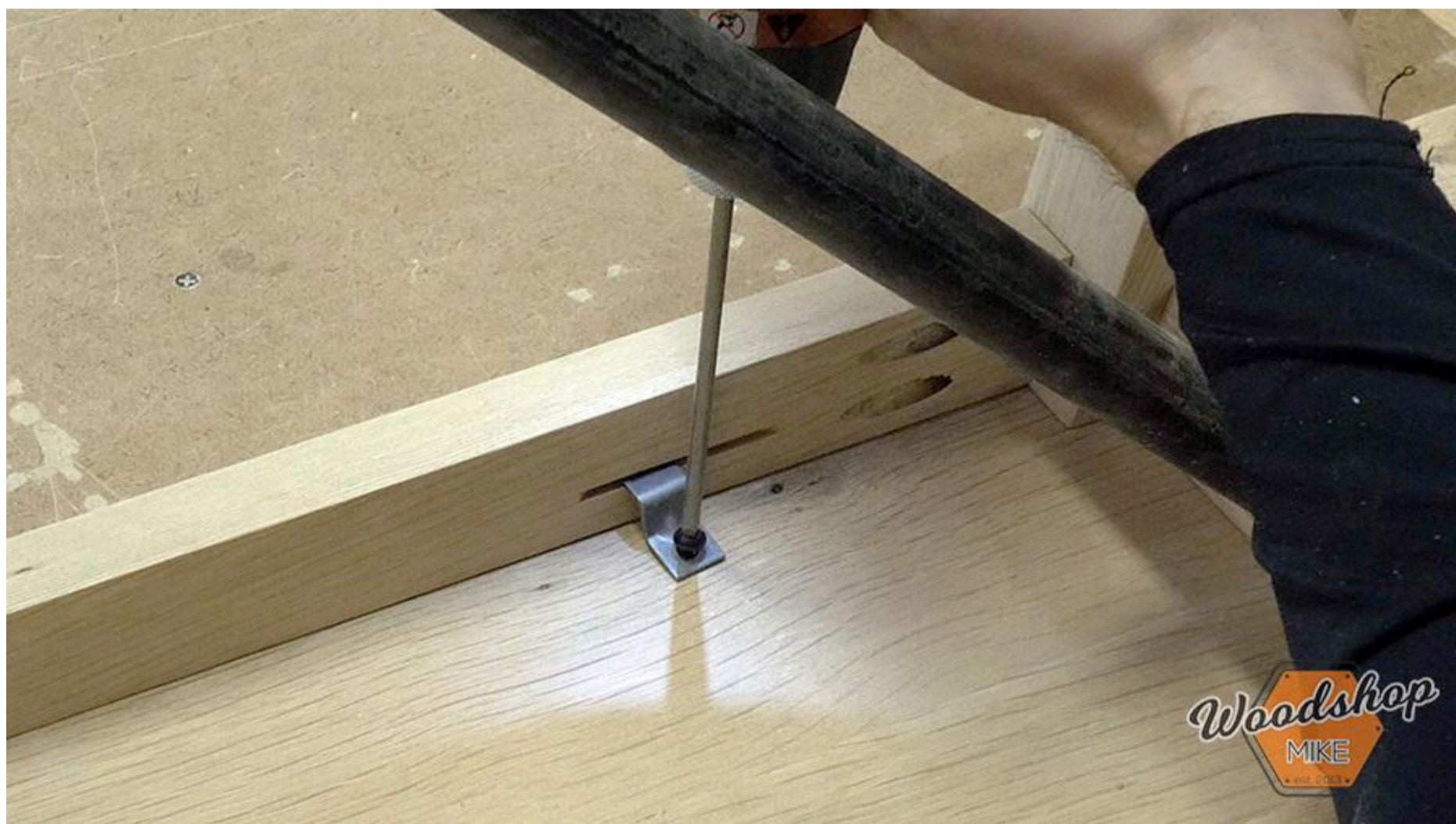

## 12

### Finish

To stain this bench, I used Varathane Weathered Wood Accelerator. Once the desired color is reached, I very lightly sand with 320 grit to knock down any grain that was raised during this process.

For finish, I really like the look and feel of Osmo Polyx-Oil. This is an easy finish to apply and provides a silky smooth surface when cured.





13

### Beauty Shot

With the bench all finished up, it's now hanging out in our entryway to great us everyday when we come home! I hope you enjoyed the build!



14

### Visit [woodshopmike.com](http://woodshopmike.com)

Go checkout this out to see more pictures of this project!

[www.woodshopmike.com/diy-farmhouse-entryway-bench](http://www.woodshopmike.com/diy-farmhouse-entryway-bench)



15

**Watch The Video!**

Check out my YouTube video to show more of this build!

<https://www.youtube.com/watch?v=gybPKYVw978>

