

# Tablet Stand

By **Kreg Tool**

Difficulty

Easy

This handy stand holds your tablet so you don't have to, and puts it at a perfect angle for use. You can even store the stand flat by removing the leg and locking it into the face.

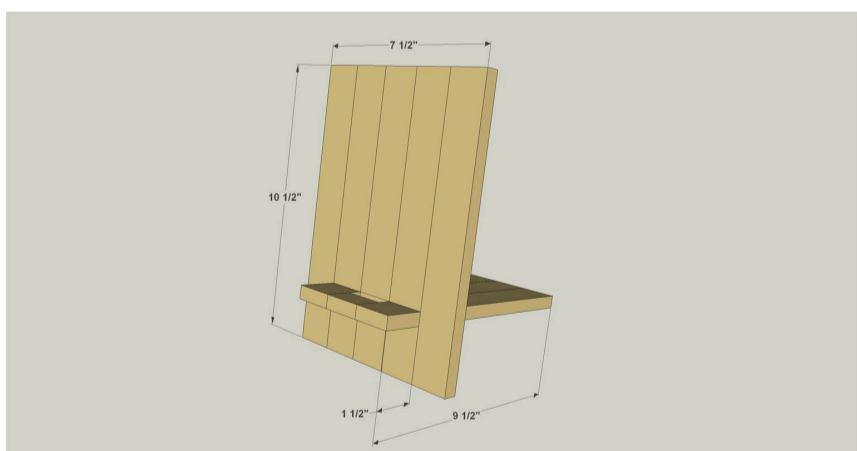
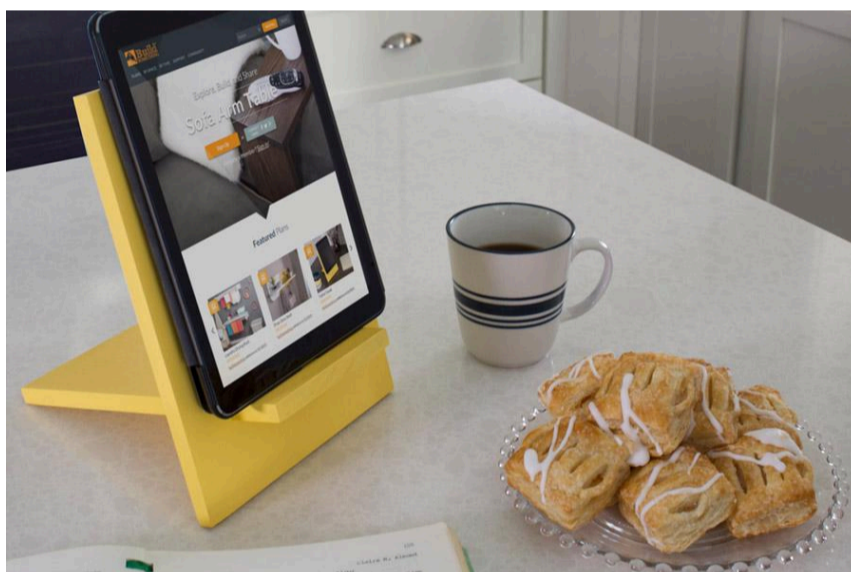

## Tools

### Kreg Tools

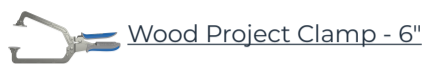

Wood Project Clamp - 6"



Kreg 20V Ionic Drive™ 5" Random Orbit Sander (Tool Only)

### Other Tools

Miter Saw

## Materials

### Wood Products

3 Board , 1/2" X 2" , 48"

### Hardware & Supplies

1 Wood Glue

1 Paint Or Finish

# Cut List & Parts

- 2 Outside Leg , 1/2" X 11 1/2" X 11 1/2"
- 1 Tall Center Leg , 1/2" X 11 1/2" X 10"
- 1 Short Center Leg , 1/2" X 11 1/2" X 2"
- 2 Outside Faces , 1/2" X 11 1/2" X 11 1/2"
- 3 Tall Inside Face , 1/2" X 11 1/2" X 8 1/2"
- 2 Short Inside Face , 1/2" X 11 1/2" X 2 1/2"
- 1 Center Face , 1/2" X 11 1/2" X 2"

**NOTE: Most parts are cut extra-long to start, then trimmed after gluing**

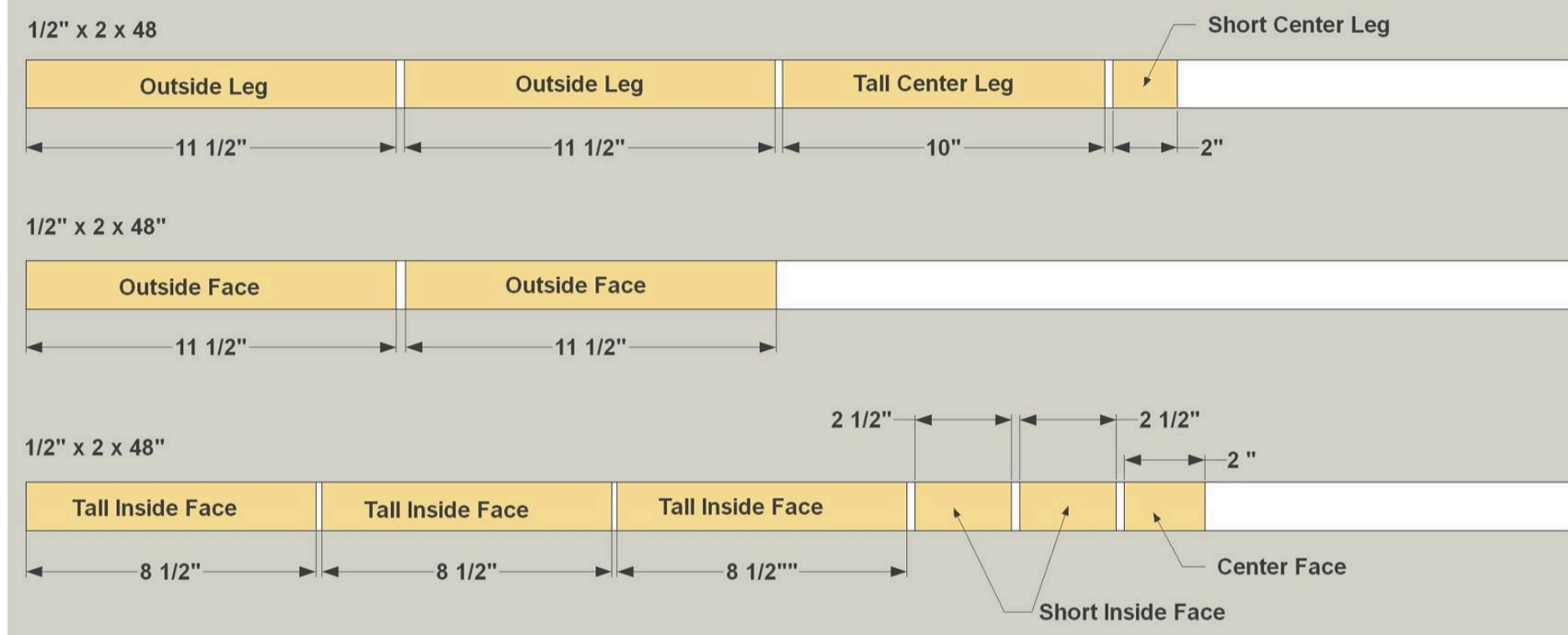

# Directions

**1****Cut the Leg Parts**

Cut two Outside Legs, one Tall Center Leg, and one Short Center Leg to length from a 1/2"-thick board, as shown in the cutting diagram.

Note: These, as well as the other parts are cut extra-long, and will be trimmed after assembly. Also cut a short piece of scrap about 2" long to use as a spacer.

**2****Assemble the Leg**

Assemble the leg parts. To do this, spread glue on both edges of the Tall Center Leg and Short Center Leg. Then clamp them to the Outside Legs, with your scrap spacer in between the Tall Center Leg and Short Center Leg. This creates a gap for the tablet's cord to pass through later. Once you have the clamps in place, remove the spacer before the glue dries to ensure that sure you don't glue the spacer in place.

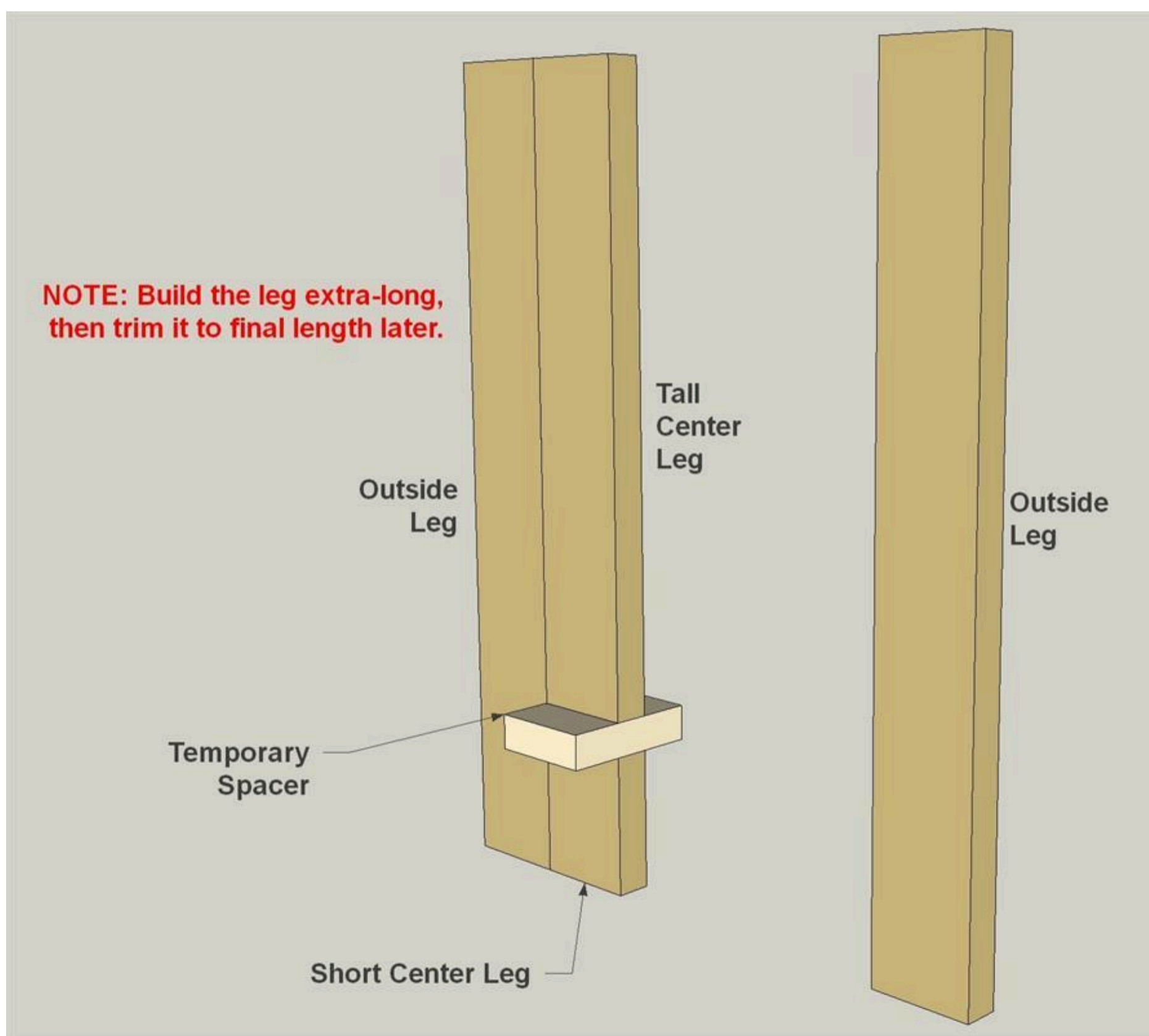

**3****Trim the Leg**

After the glue sets, you can trim the leg. You'll cut some off the top end to create a Leg Stop, and then cut the bottom end (near the slot) to trim the Leg to final length.

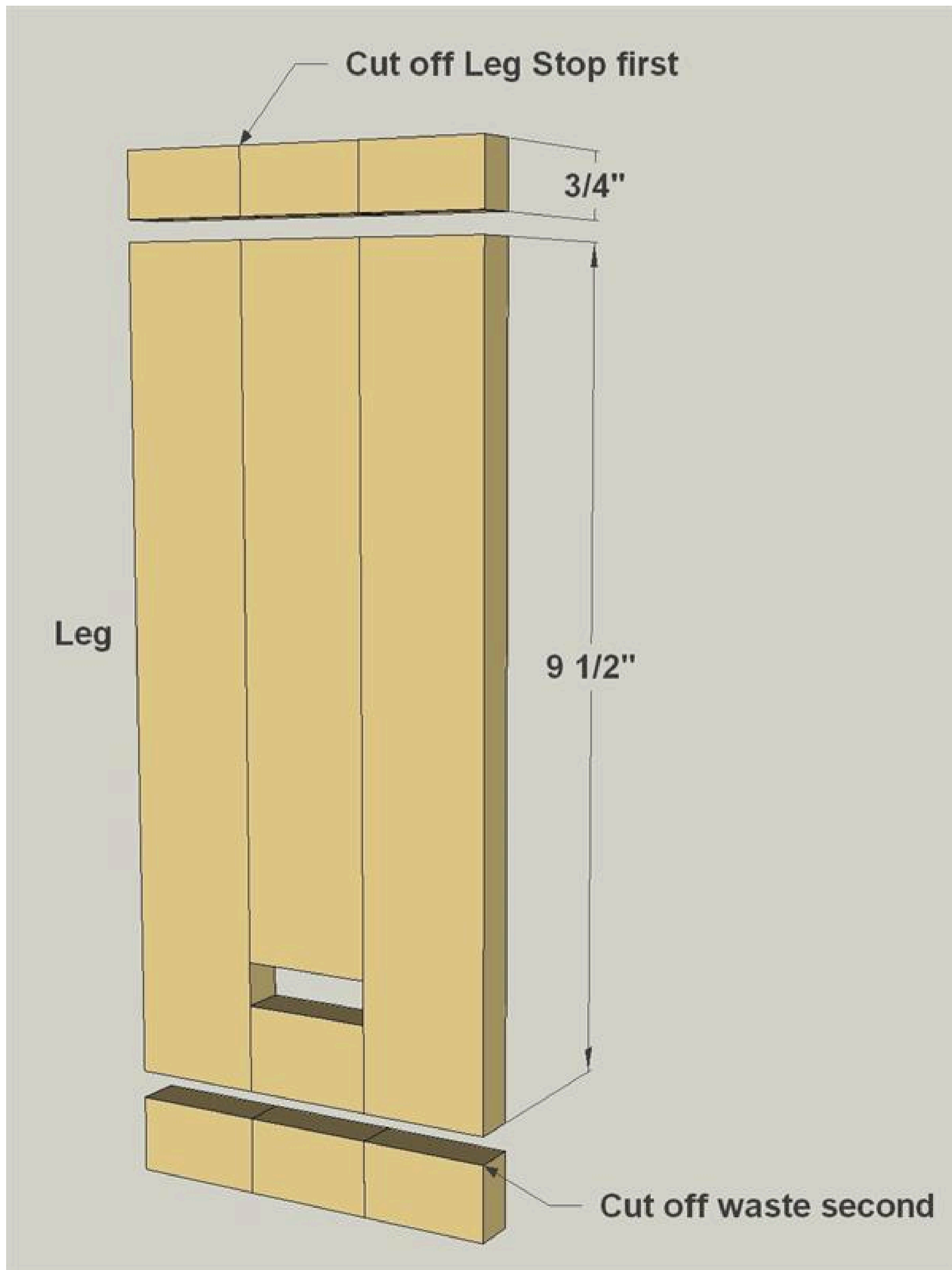

**4****Glue on the Leg Stop**

Glue the Leg Stop, which you cut off of the top of the leg assembly, onto the leg as shown.

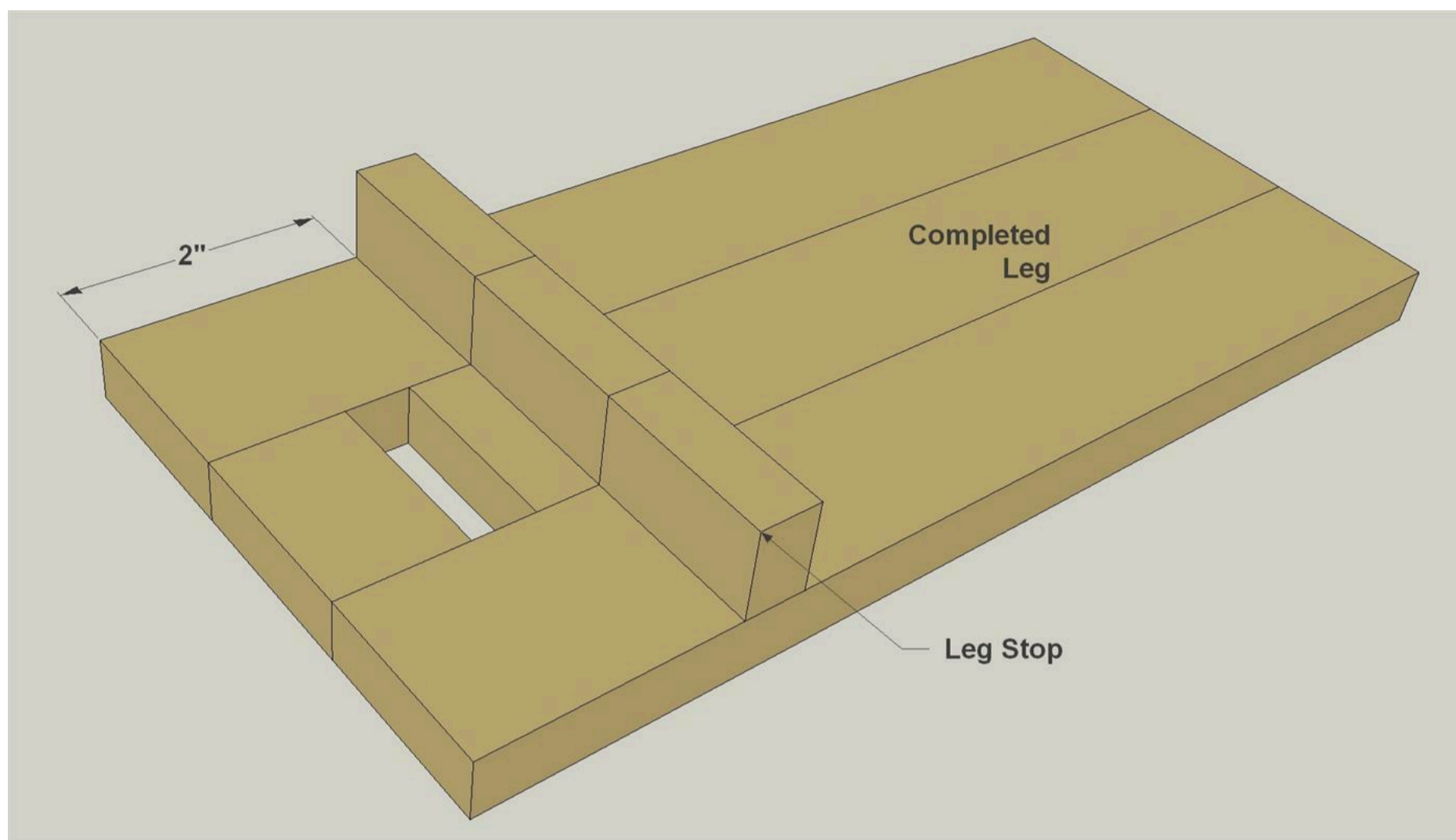
**5****Cut the Face Parts**

Cut two Outside Faces, three Tall Inside Faces, one Short Inside Face, and one Center Face to length from a 1/2"-thick board, as shown in the cutting diagram. Note: These, as well as the other parts are cut extra-long, and will be trimmed after assembly. Also cut another spacer about 4" long.

**6****Assemble the Face**

Assemble the face parts. To do this, spread glue on both edges of the Tall Inside Faces, Short Inside Faces, and Center Face. Then clamp them to the Outside Faces, with your scrap spacers positioned to create the center slot and notch. The slot will allow the leg to slip through the face, and the notch provides cord clearance. Once you have the clamps in place, remove the spacers before the glue dries to ensure that sure you don't glue them in place.

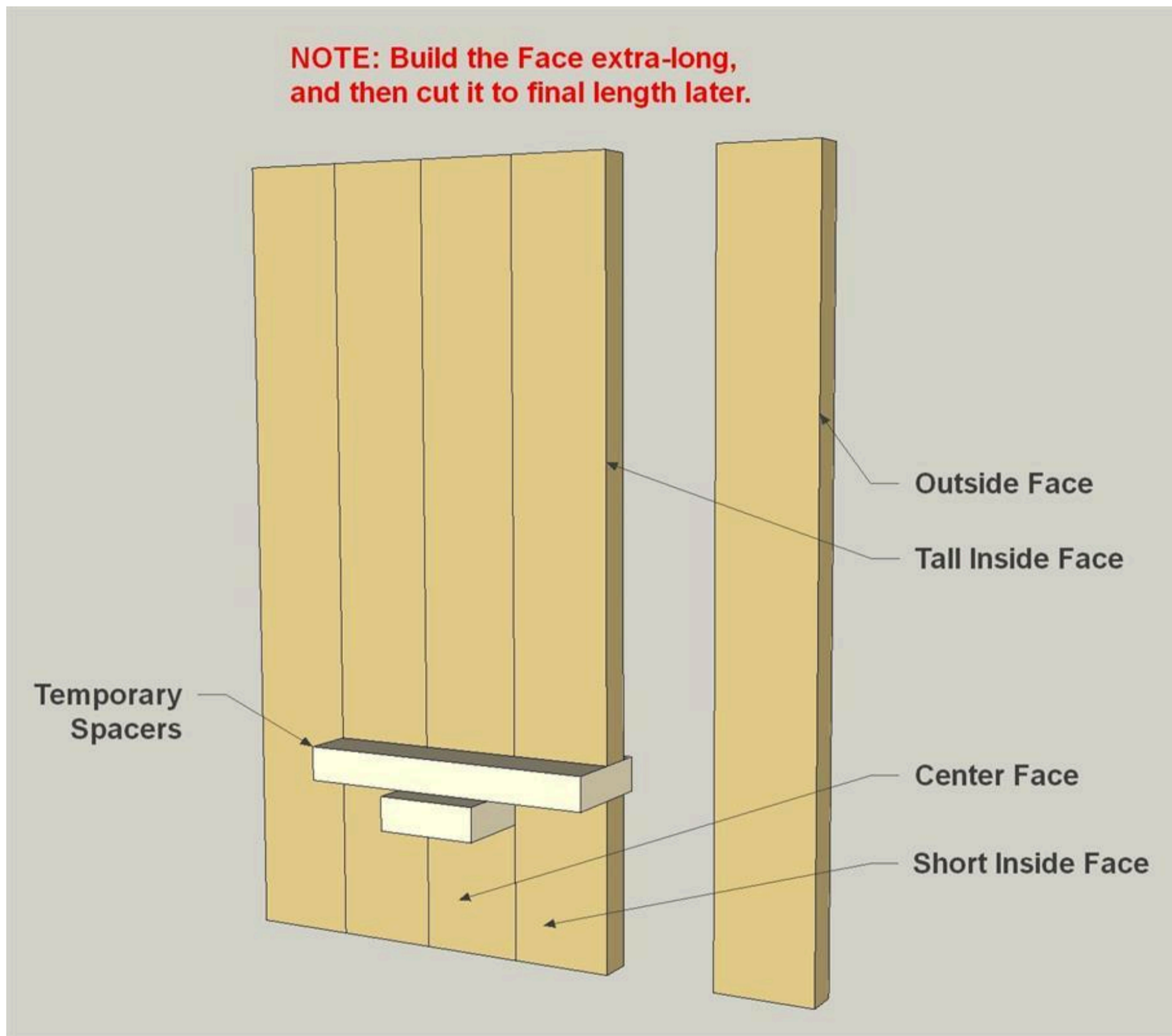

7

**Trim the Face**

After the glue sets, you can trim the Face. You'll cut some off the bottom end (near the slot) first, and then cut the top end to trim the Face to final length.

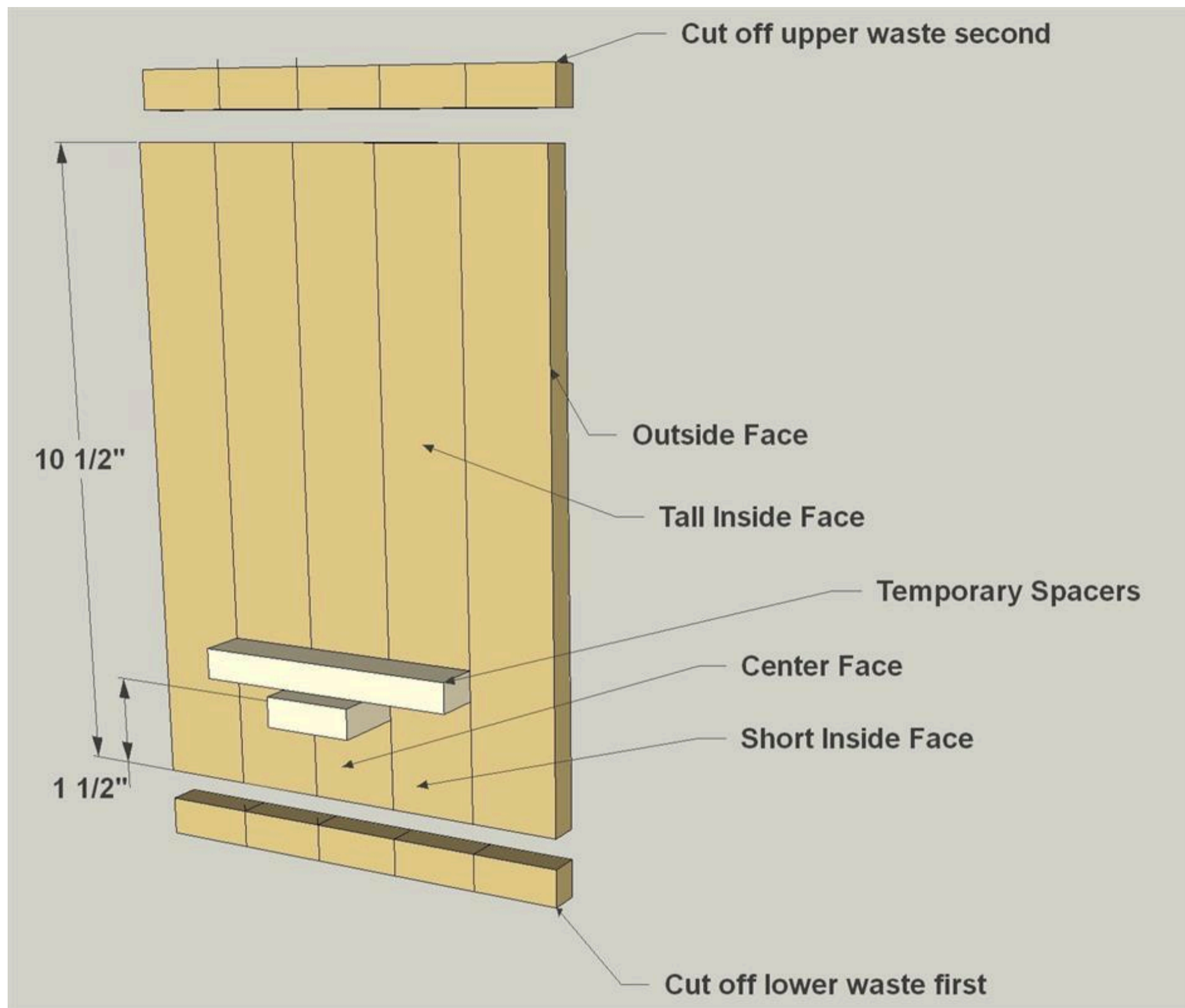

8

**Test Fit, then Finish**

Now you can test fit the leg into the slot. If the fit is tight, sand or file to enlarge the slot. Do this just a little at a time to make sure that you don't take off too much. After that, you can paint or finish your tablet stand and put it to work.