

Decorative DIY Candle Holders

By **Kreg Tool**

Difficulty

Easy

Whether you're decorating for the holidays, making gifts, or just looking for a fun decor idea, this trio of candle holders fills the bill. You can create all three quickly and easily by cutting apart a single 2"-diameter dowel from the home center. Then spray on a paint color that suits your style.

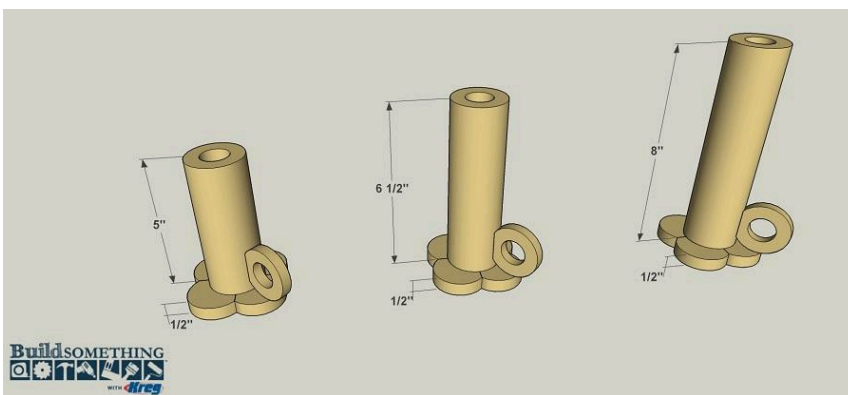

Tools

Kreg Tools

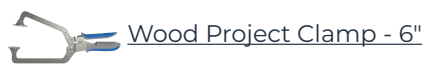

Other Tools

Square

Tape Measure

Miter Box

Drill (cordless)

Materials

Wood Products

1 Wood Dowel , 2"-diameter , 48"

Hardware & Supplies

1 1" Forstner Bit

1 Wood Glue

Cut List & Parts

- 1 Short Stem , 2" X 5" Poplar Dowel
- 1 Medium Stem , 2" X 6 1/2" Poplar Dowel
- 1 Tall Stem , 2" X 8" Poplar Dowel
- 3 Handle , 2" X 1/2" Poplar Dowel
- 12 Base , 2" X 1/2" Poplar Dowel

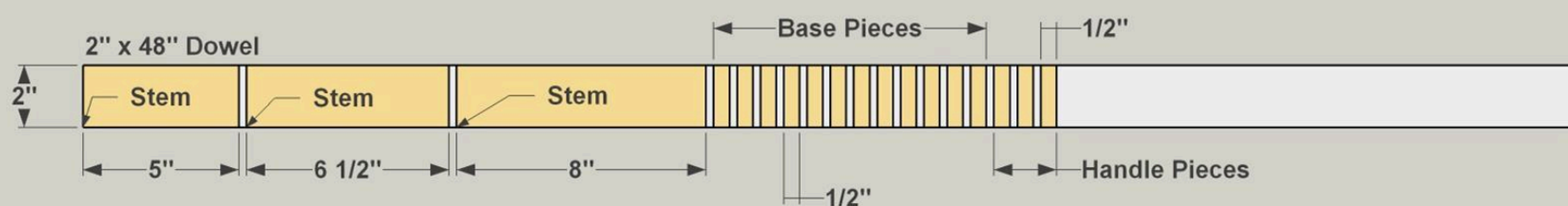

Directions

1**Select Your Sizes (and Saw)**

Before you begin, decide what size candle holders you want to create. The cutting diagram and plan show how to get all three sizes from one 48" dowel. The parts are the same for each size, except for the length of the stems. Also, you may want to consider an inexpensive miter box as the cutting tool of choice for this project. A miter box works like a miter saw, but uses a hand saw and a simple guide box to cut 90°, 45° and some other angles. By using a miter box, you can make cut these small pieces safely and with control. Plus, you can pick up a miter box for \$15 or less in any home center

2**Cut the Stems and Drill Holes**

Start by cutting the three Stems to length from a 2" poplar dowel, as shown in the cutting diagram. Now, secure a clamp at the base of the first Stem, and then use another clamp to hold the Stem securely on a work surface (see the Tip below). Mark the center of the end on the Stem, and then drill a 1"-diameter hole 1" deep. A spade bit can work for this, but a Forstner bit offers more control and cleaner results. Repeat this process for the other two stems and then set them aside for the moment.

3**Cut Thin Slices from the Dowel**

Cut twelve 1/2"-thick Base pieces from the remaining dowel using your miter box, as shown in the cutting diagram. Make sure as you cut that all of these pieces are the same thickness.

4**Shape the Base Parts**

On one Base piece, lay out two lines, as shown, to create a 90-degree corner. Cut on these two lines, once again using the miter box. Sand the flat edges as needed. Using this piece as a pattern, mark and cut the balance of the Base pieces.

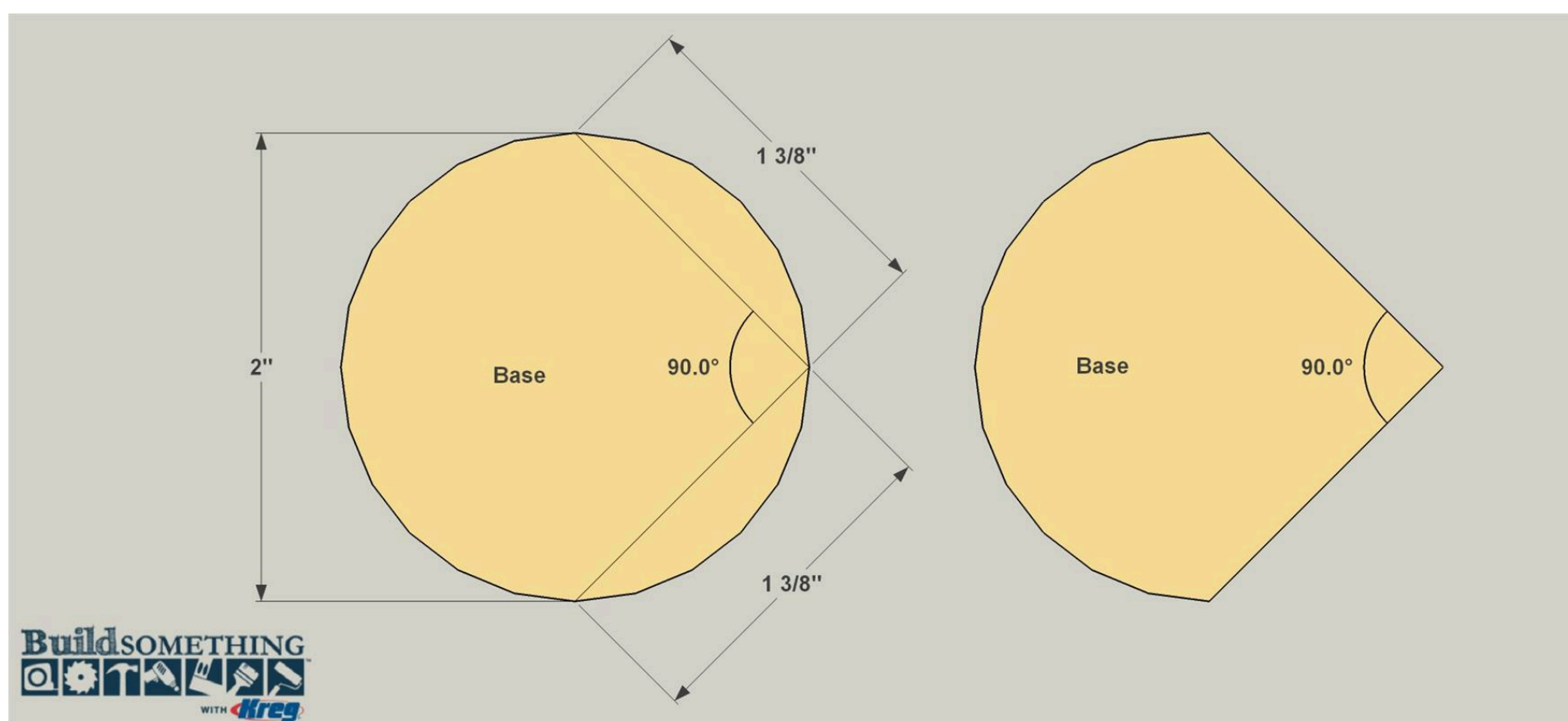

5

Assemble the Bases

Group four Base pieces together as shown. Sand the flat edges as needed to create a tight fit to the mating pieces. Glue the Base pieces together and secure them using a rubber band as a clamp. Repeat this for the other two Bases. When the glue is dry, sand the Bases to flatten them.

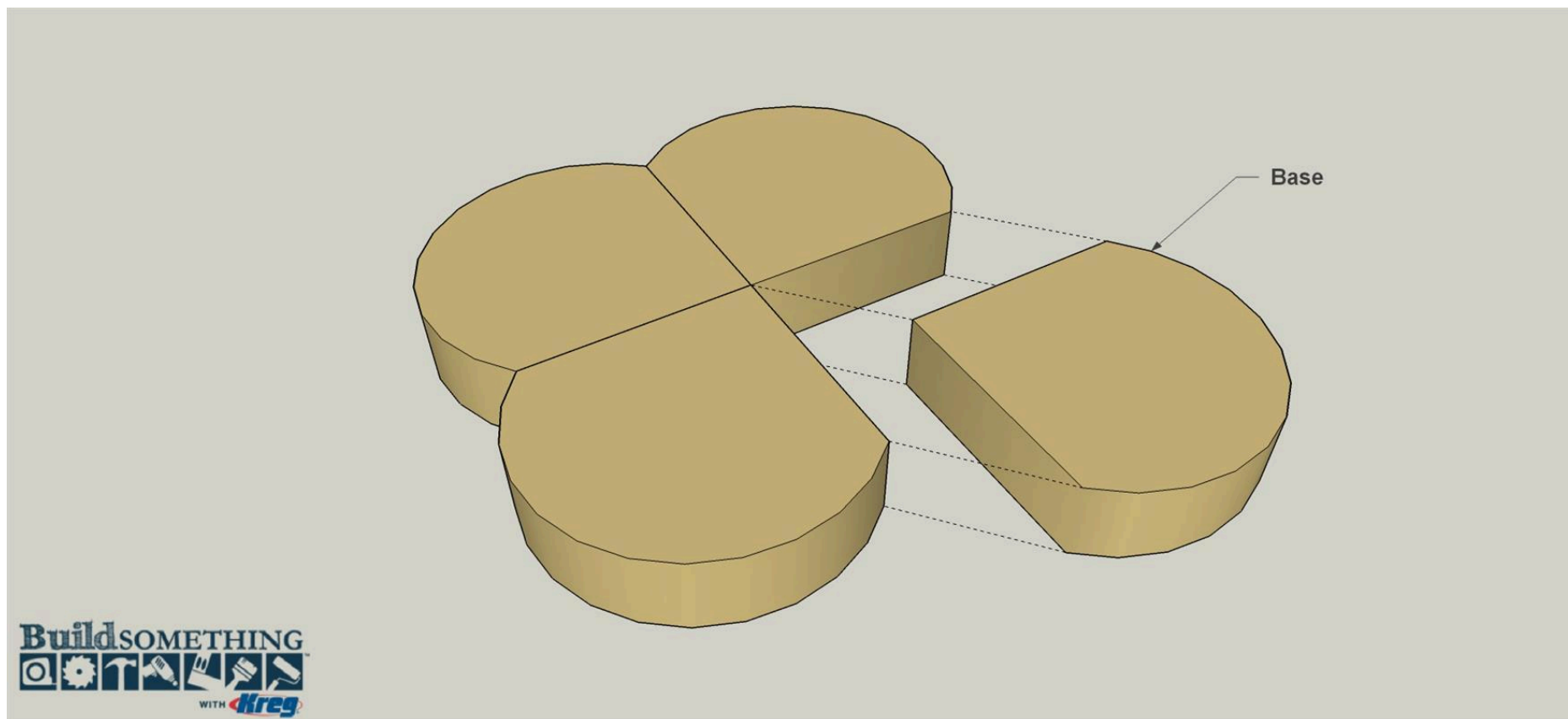

6

Attach the Stem to the Base

Now you can attach the Stem to the base assemblies you created in Step 4. Position the Stem so it's centered on the Base assemblies, as shown, and then glue it in position. Use a clamp, or rubber bands once again, to hold the pieces while the glue dries.

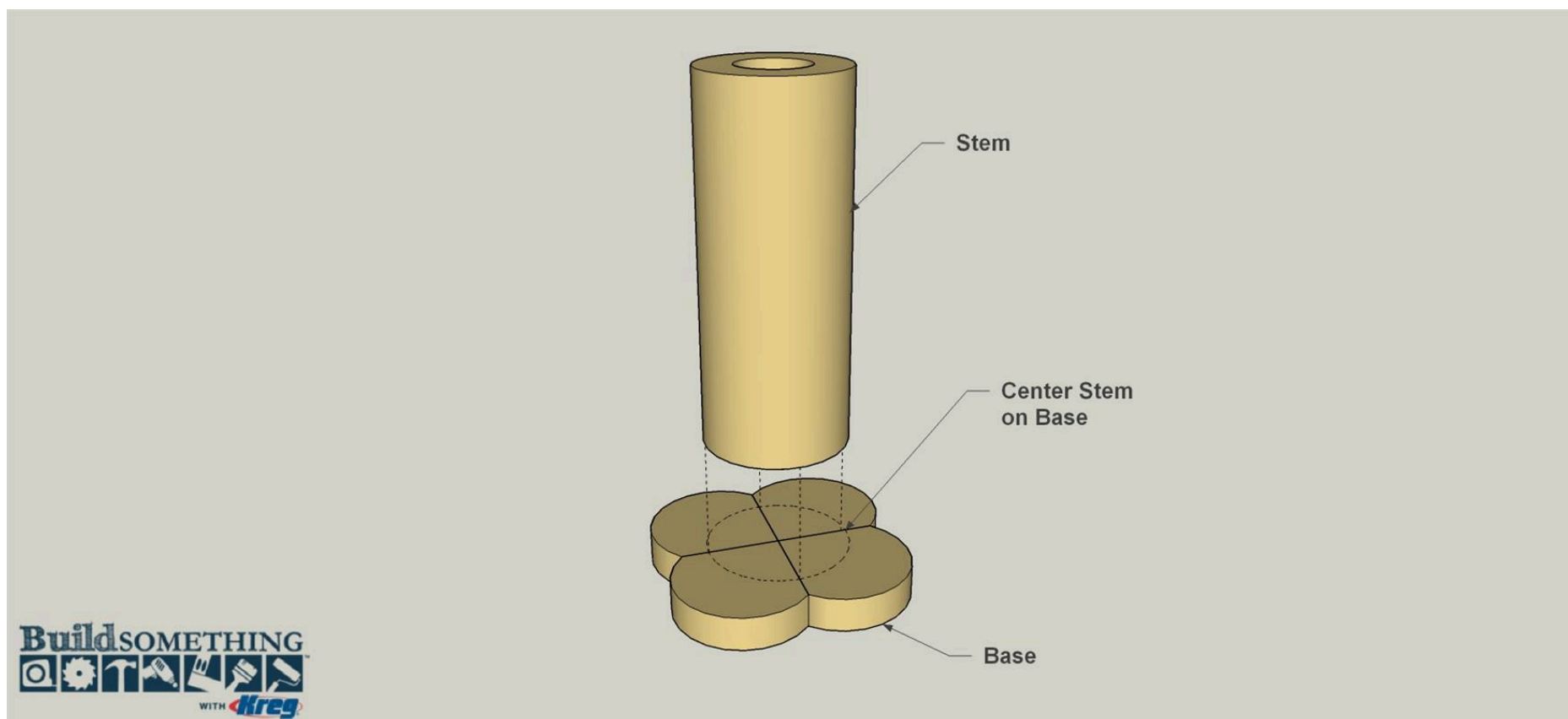

7

Make the Handles

From the remaining dowel, cut a piece about 6" long. Using the same clamping technique as in Step 2, drill a centered 1"-diameter hole in this piece. Make the hole about 2" deep. Then cut three 1/2"-thick pieces off the end of the dowel to create the Handles, as shown in the cutting diagram. Sand the surfaces and inner edges of the hole as needed. Next, you need to sand a 1"-long concave surface on each Handle so you can attach it to the Stem. An easy way to do that is shown in the Tip below.

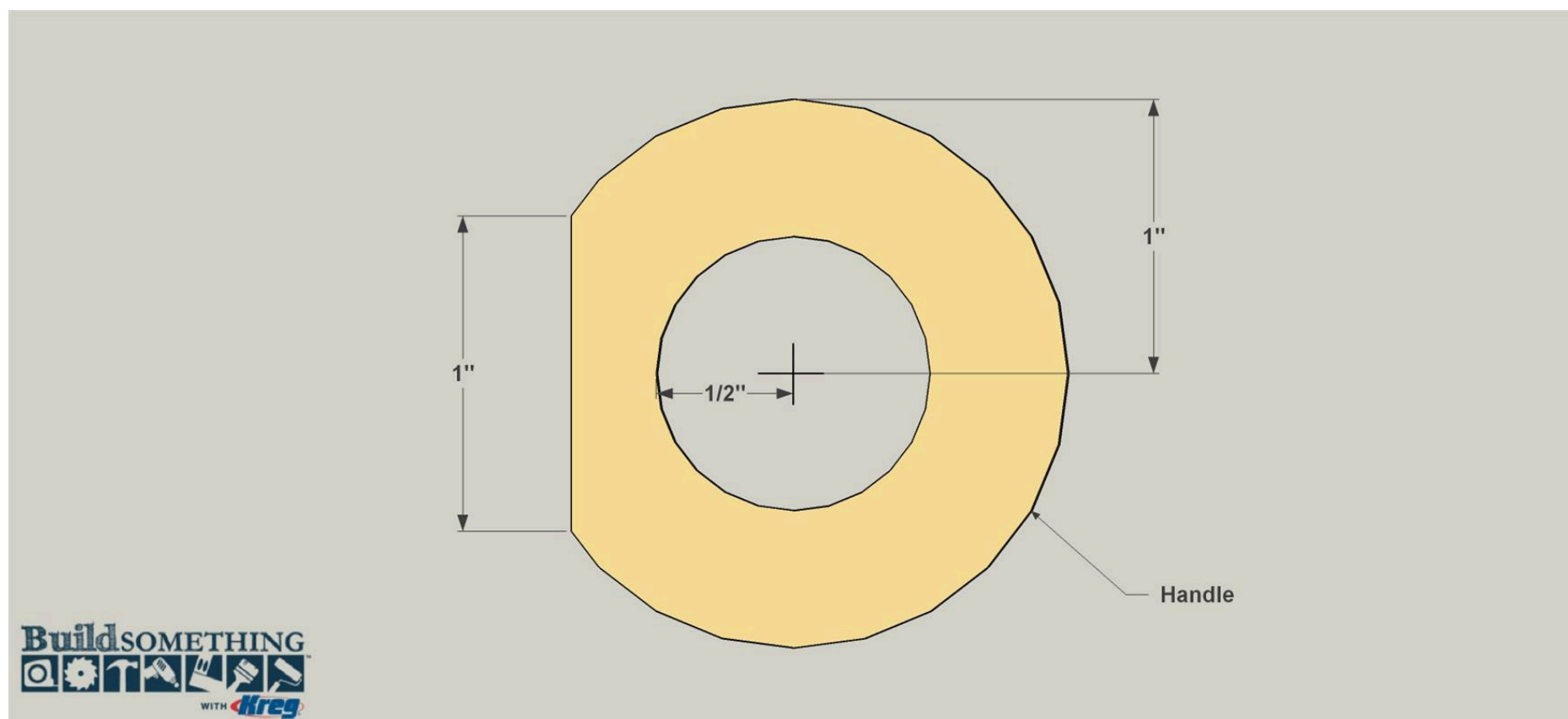

8

Attach the Handle to the Stem

Position the Handle on the Stem as shown. Apply glue to the edges of the Handle that contact both the Stem and Base, and gently secure it with a clamp or rubber band until the glue dries.

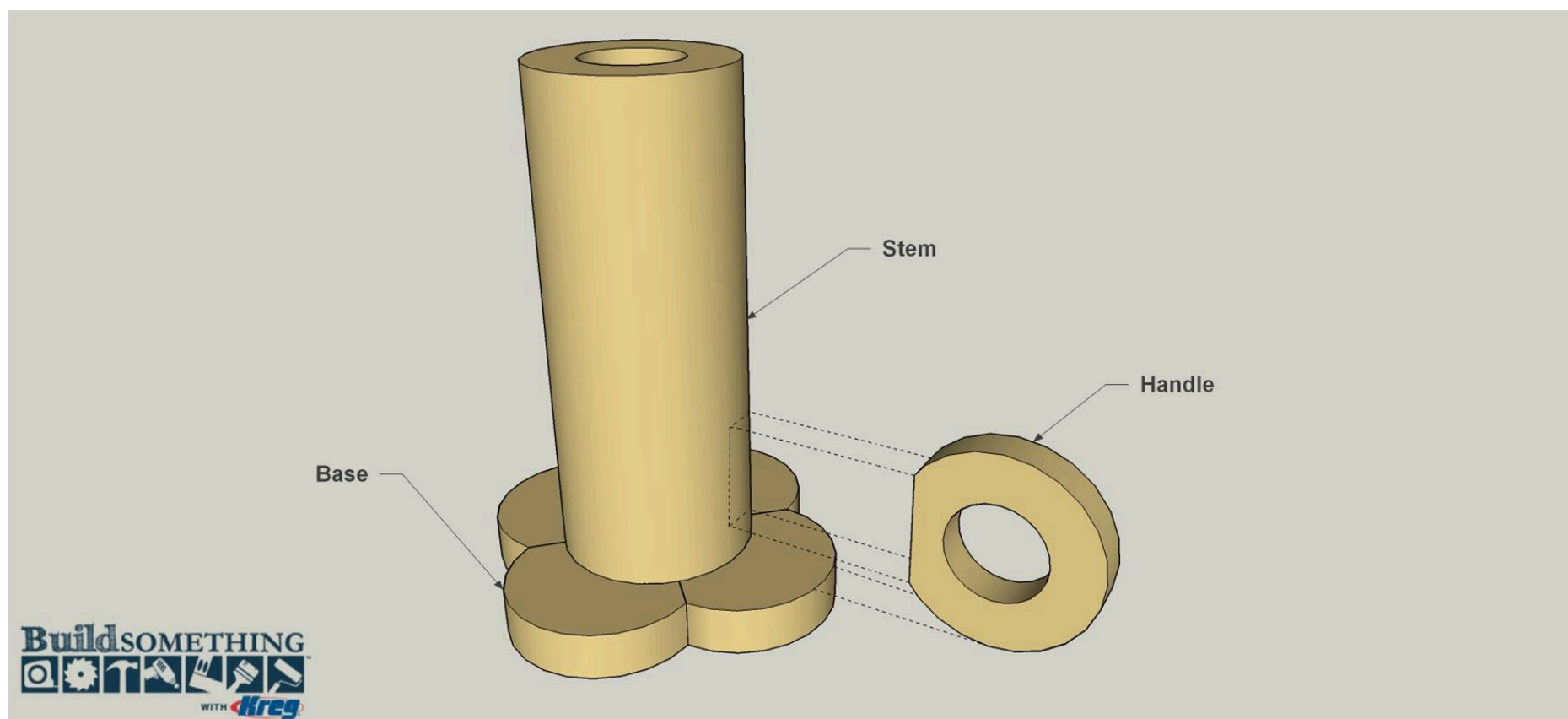

9

Apply Paint to Finish Up

To finish off the piece, sand all of the surfaces and edges smooth, as needed. Then you can paint the candle holders. We used a couple a couple of coats of gold metallic spray paint for a traditional look.
