

Classic Dining Room Sideboard

By **Kreg Tool**

Difficulty

Advanced

Add some serious style and storage in your dining room by building this great-looking sideboard. It offers two enclosed compartments for storage, open shelves that are perfect for display, and a generous top surface that's perfect for laying out the spread you intend to serve.

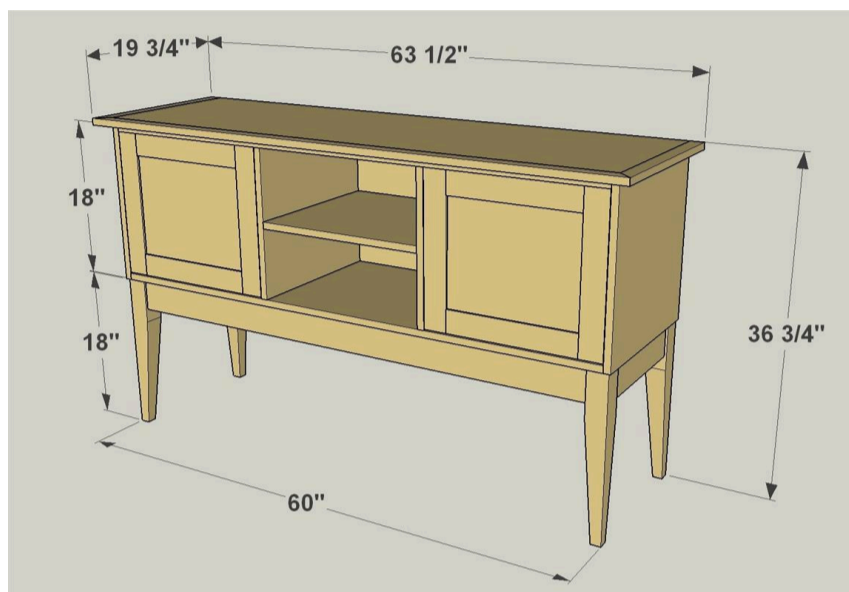

Tools

Kreg Tools



[Kreg® Pocket-Hole Jig 720](#)

Other Tools

Circular Saw (corded)

Miter Saw

Tape Measure

Drill (cordless)

Sander

Materials

Wood Products

2 Board , 1x2 , 96"

2 Board , 1x3 , 96"

2 Board , 1x4 , 96"

2 Plywood , 3/4" Thick , Full Sheet

1 Plywood , 1/2" Thick , Full Sheet

Hardware & Supplies

4 2 3/4" X 18" Tapered Table Legs

87 1 1/4" Fine-thread Pocket Hole Screws

68 1 1/4" Coarse-thread Pocket Hole Screws

16 1 1/2" Fine-thread Pocket Hole Screws

4 2" Cabinet Door Hinges

2 Door Catches

1 Wood Glue

Cut List & Parts

- 1 Top , 3/4" Plywood X 18 1/4" X 60 1/2"
- 1 Top Front Edge , 3/4" X 1 1/2" X 63 1/2"
- 2 Top Side Edge , 3/4" X 1 1/2" 19 3/4"
- 1 Case Top , 3/4" Plywood X 18 1/4" X 59"
- 1 Case Bottom , 3/4" Plywood X 18 1/4" X 59"
- 2 Case Sides , 3/4" Plywood X 18 1/4" X 18"
- 2 Case Divider , 3/4" Plywood X 17 3/4" X 16 1/2"
- 1 Case Shelf , 3/4" Plywood X 17 3/4" X 19"
- 1 Case Back , 1/2" Plywood X 16 1/2" X 59"
- 2 Door Panel , 1/2" Plywood X 14 1/8" X 11 3/8"
- 4 Door Rail , 3/4" X 2 1/2" X 14 1/8"
- 4 Door Stile , 3/4" X 2 1/2" X 16 3/8"
- 2 Base Front/ Back Rail , 3/4" X 3 1/2" X 55 1/2"
- 2 Base Side Rail , 3/4" X 3 1/2" X 13 1/2"
- 4 Corner Brace , 3/4" X 3 1/2" X 5 1/16"
- 4 Leg , 2 1/4" X 2 1/4" X 18"

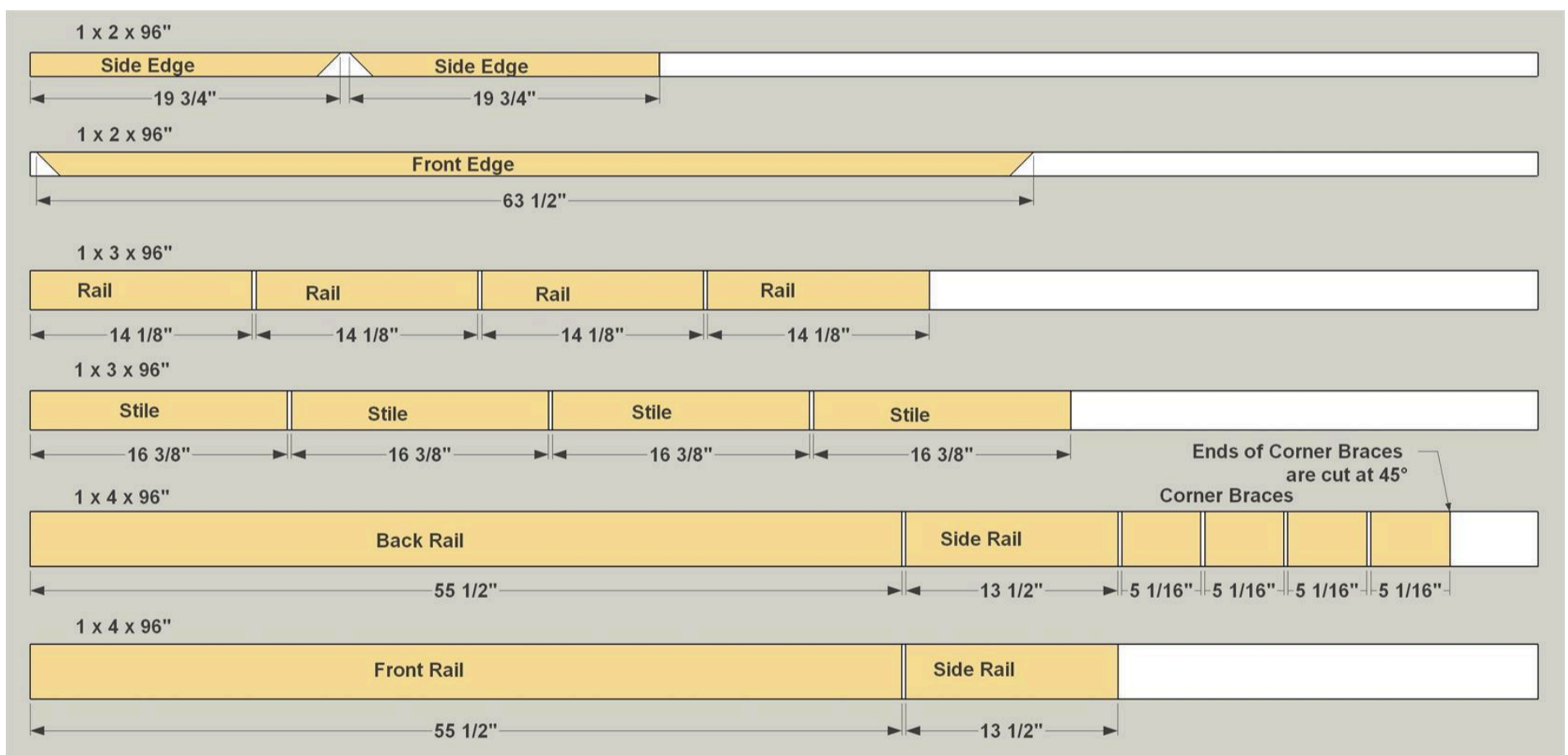

3/4" plywood x 48 x 96

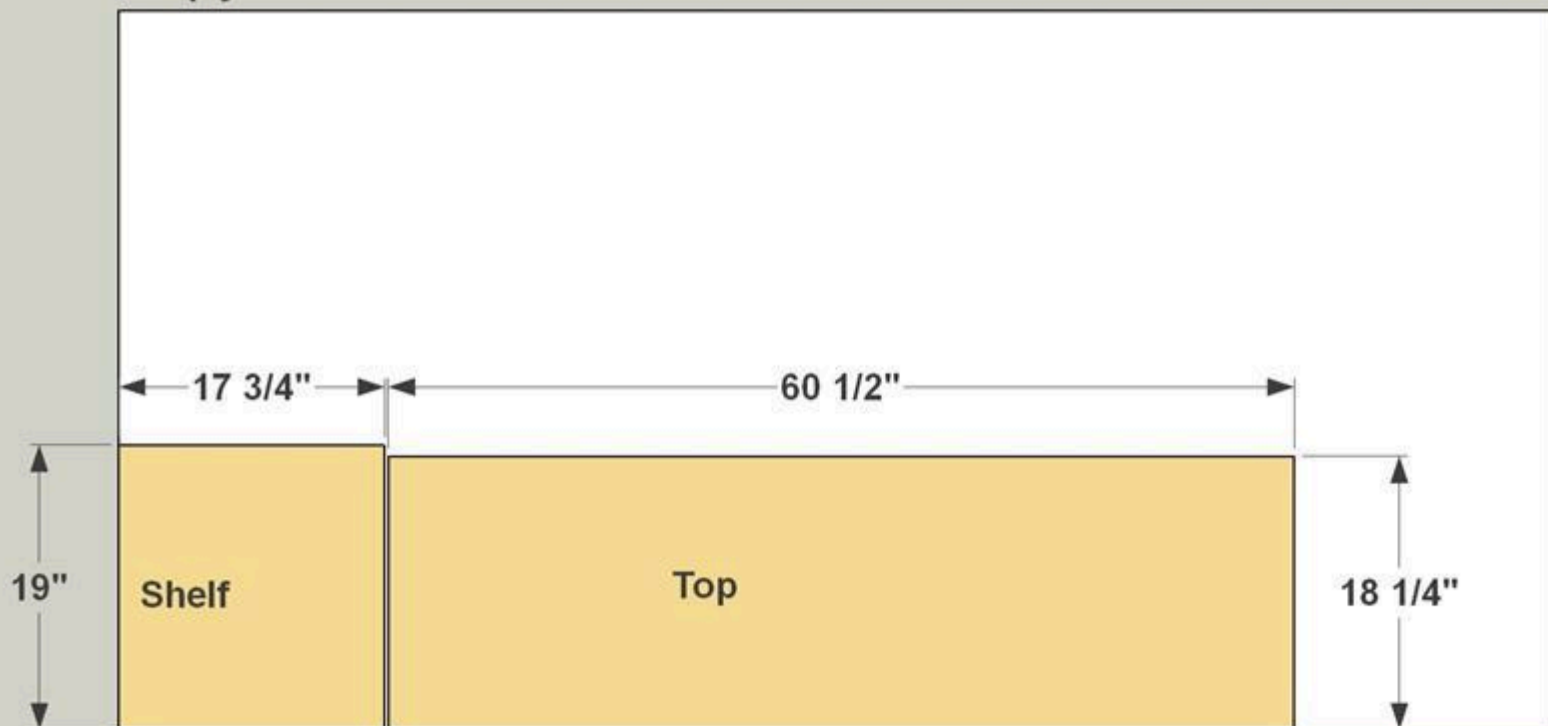

3/4" plywood x 48 x 96

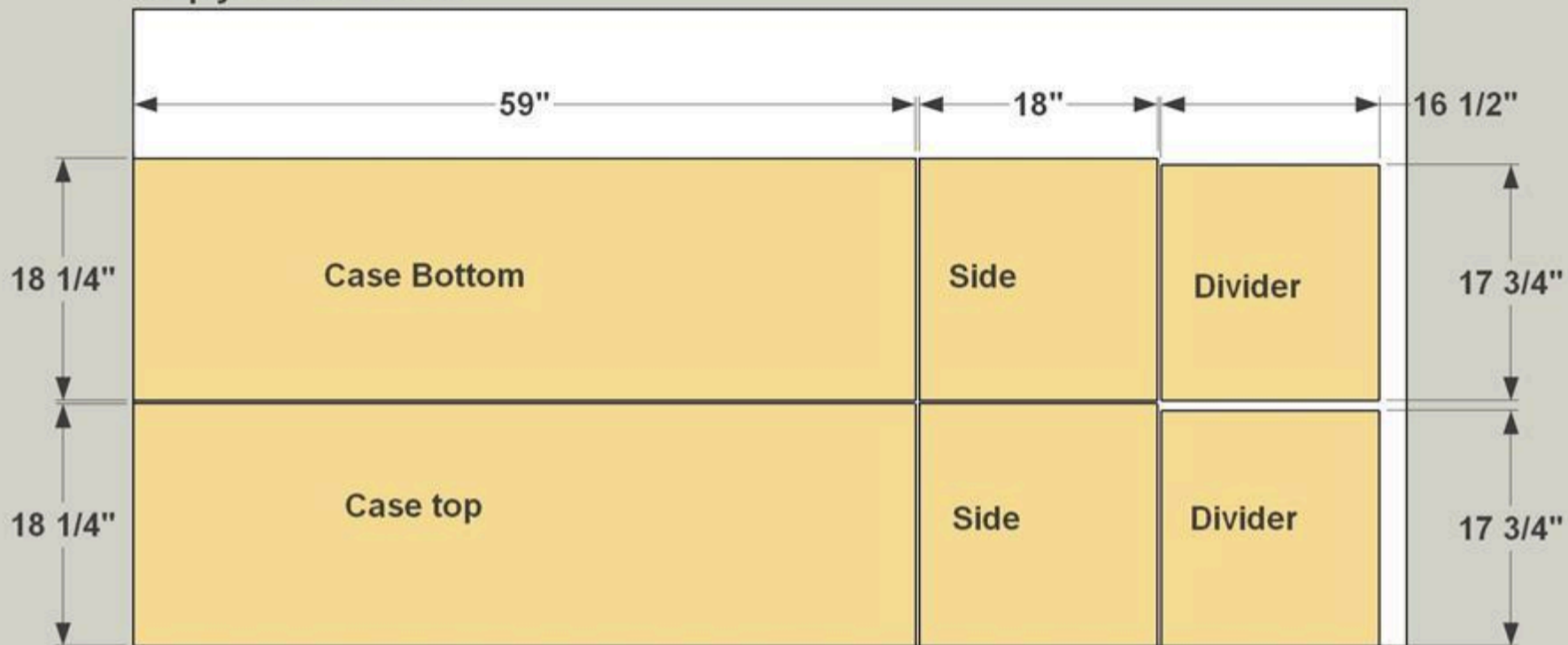

1/2" plywood x 48 x 96

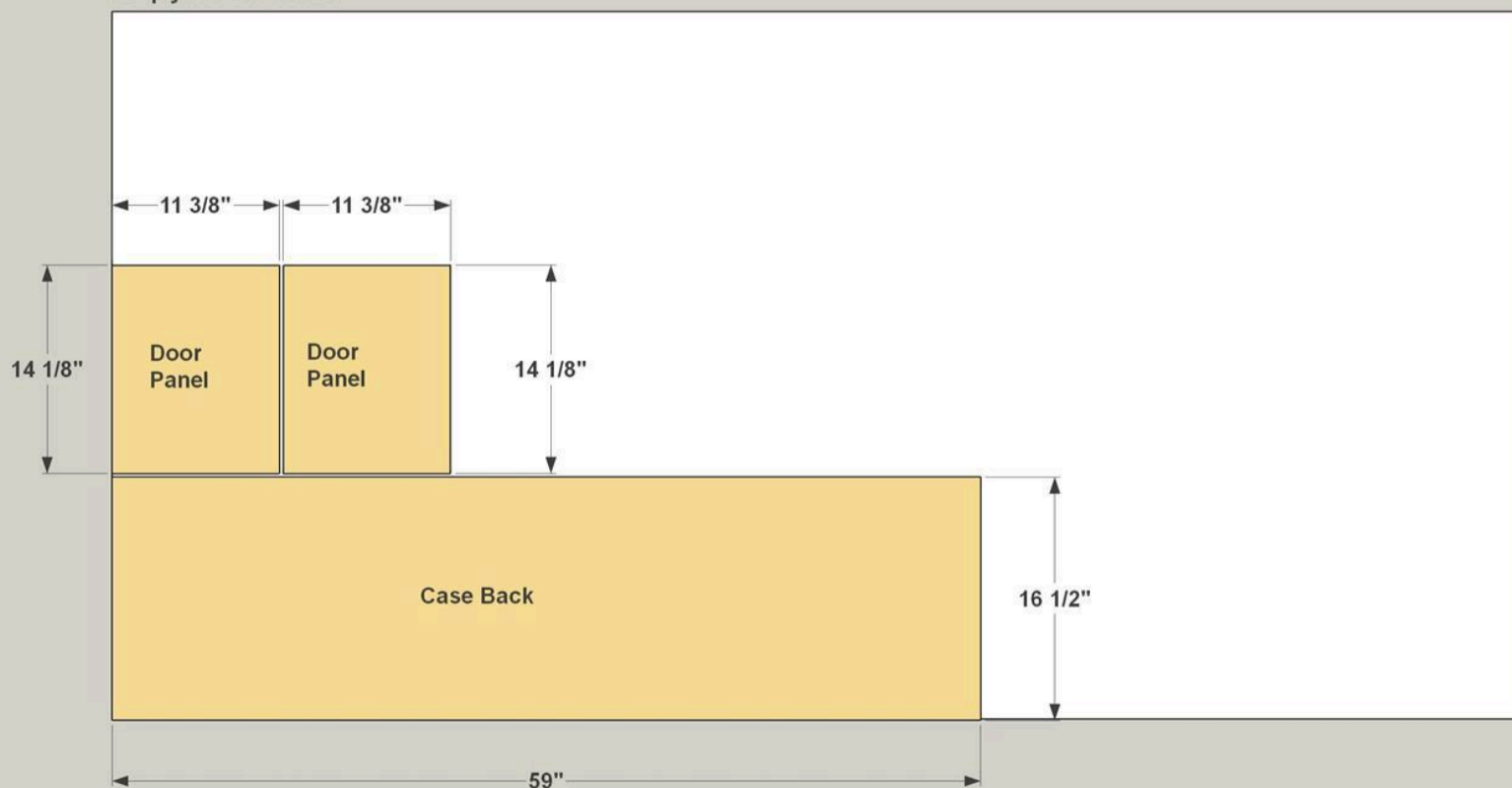

Directions

1

Start with Base Side Rails

Cut two Base Side Rails to length from a 1x4 board (we used maple), as shown in the cutting diagram. Then, with your pocket hole jig set up for 3/4" material, drill pocket holes in the back face of the End Rails, as shown.

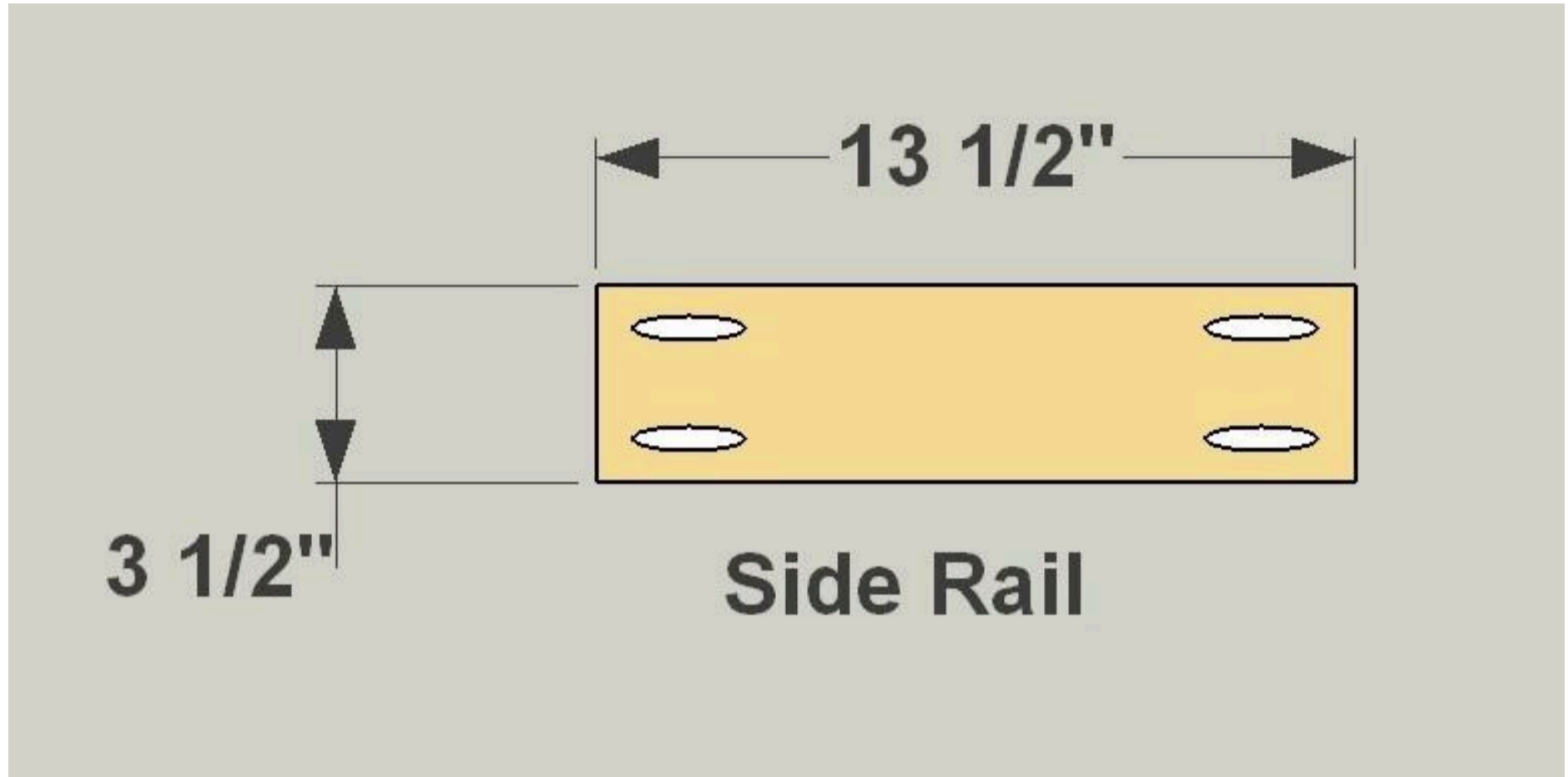

2**Connect End Rails and Legs**

When your Legs arrive, sand them as needed. Then attach the End Rails to the Legs using 1 1/4" fine-thread pocket hole screws. Make sure that the Tapers are pointing inward, and that the End Rails are inset 1/4" from the outside of the Legs.

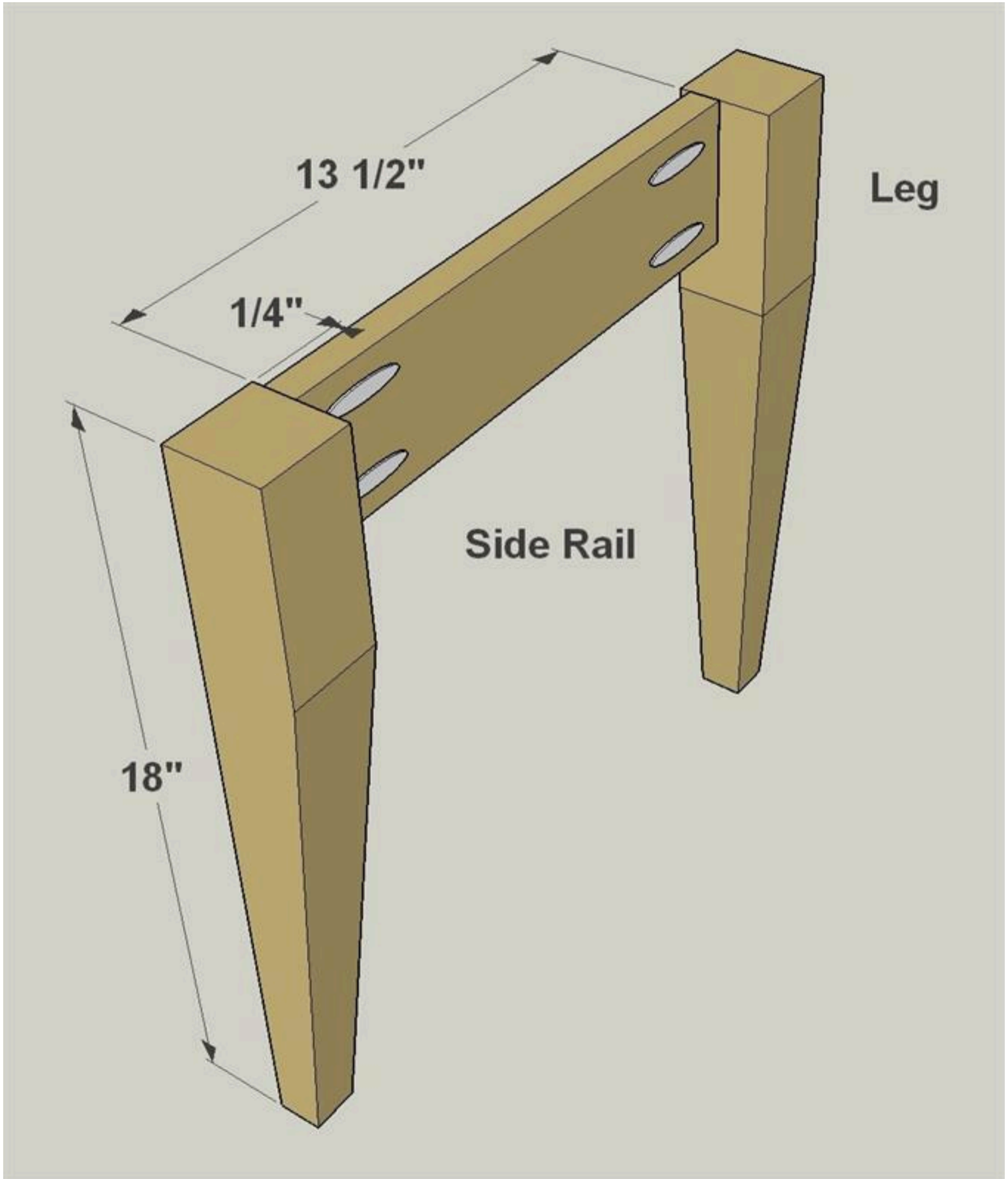

3**Make the Front and Back Rails**

Cut a Base Front Rail and a Base Back Rail s to length from a 1x4 board, as shown in the cutting diagram. Then, with your pocket hole jig set up for 3/4" material, drill pocket holes in the back face of these Rails, as shown.

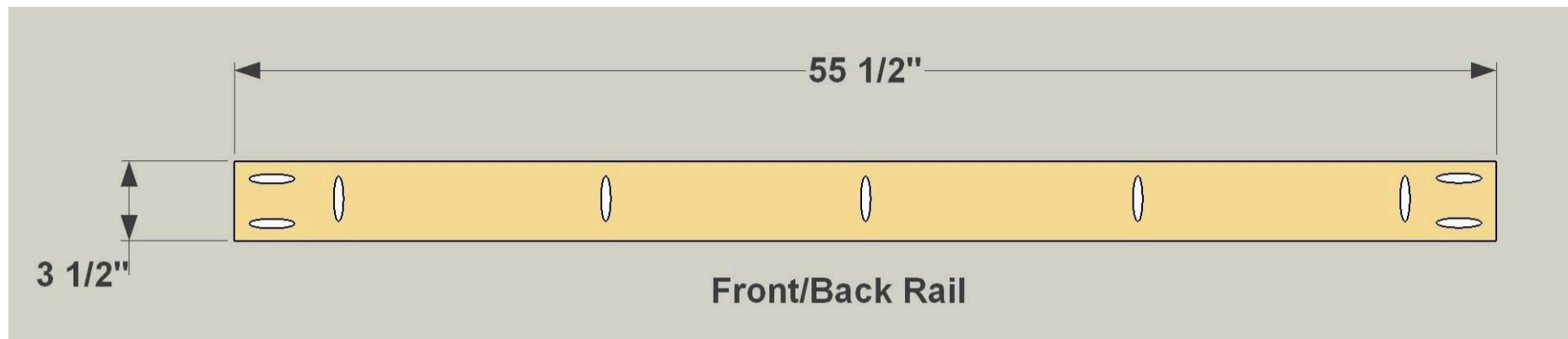

4

Connect the End Assemblies

Attach the Front and Back Rails to one end assembly with 1 1/4" fine-thread pocket hole screws. Make sure the Rails are 1/4" inset from the outside edge of the legs. Then connect the other end assembly the same way.

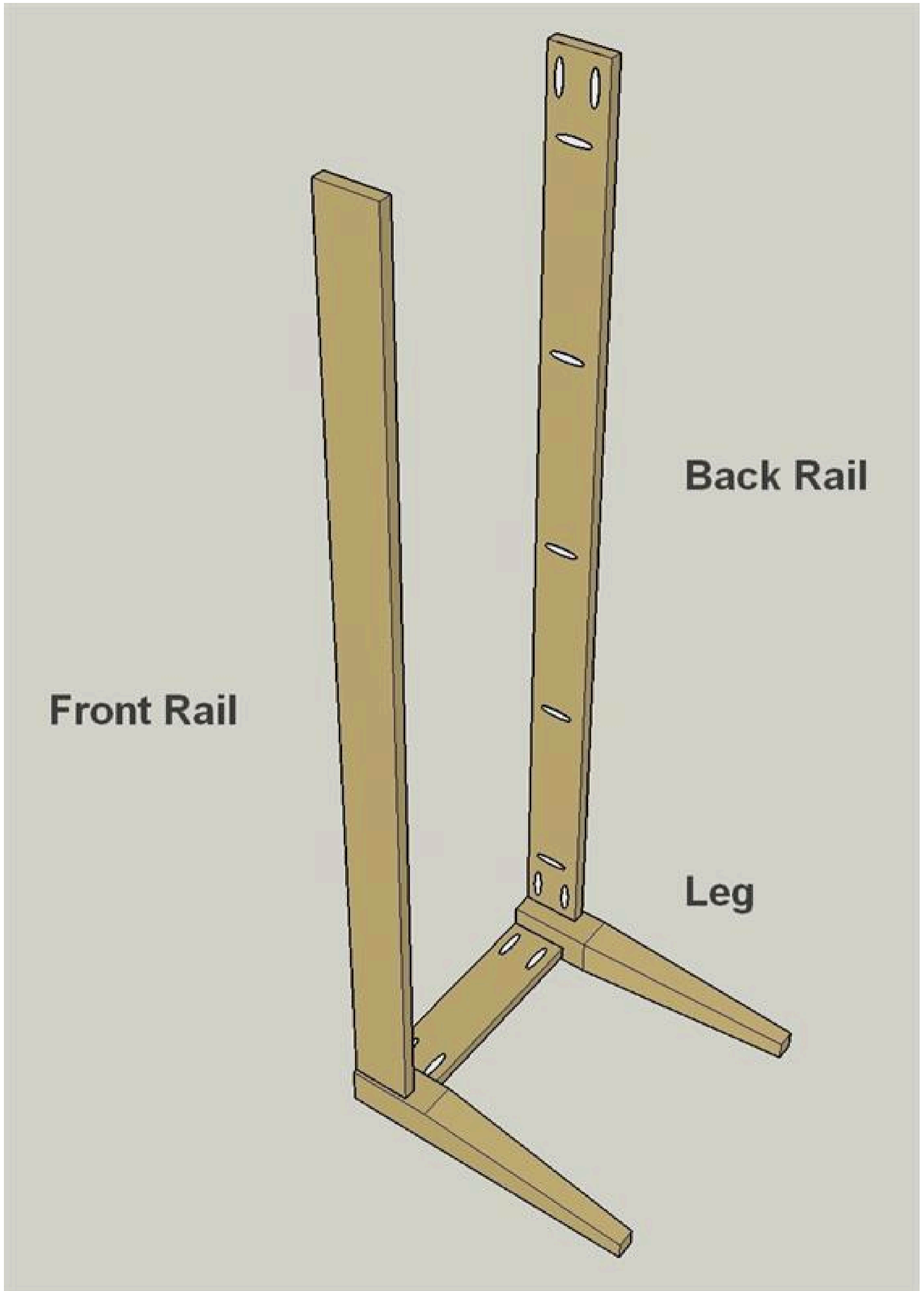

5**Make Corner Braces**

Cut four Corner Braces to length from a 1x4 board, as shown in the cutting diagram. Note that the ends are cut at 45° so the braces can span between the Rails. Drill pilot holes straight through the Braces at the locations shown for screws that will hold them in place.

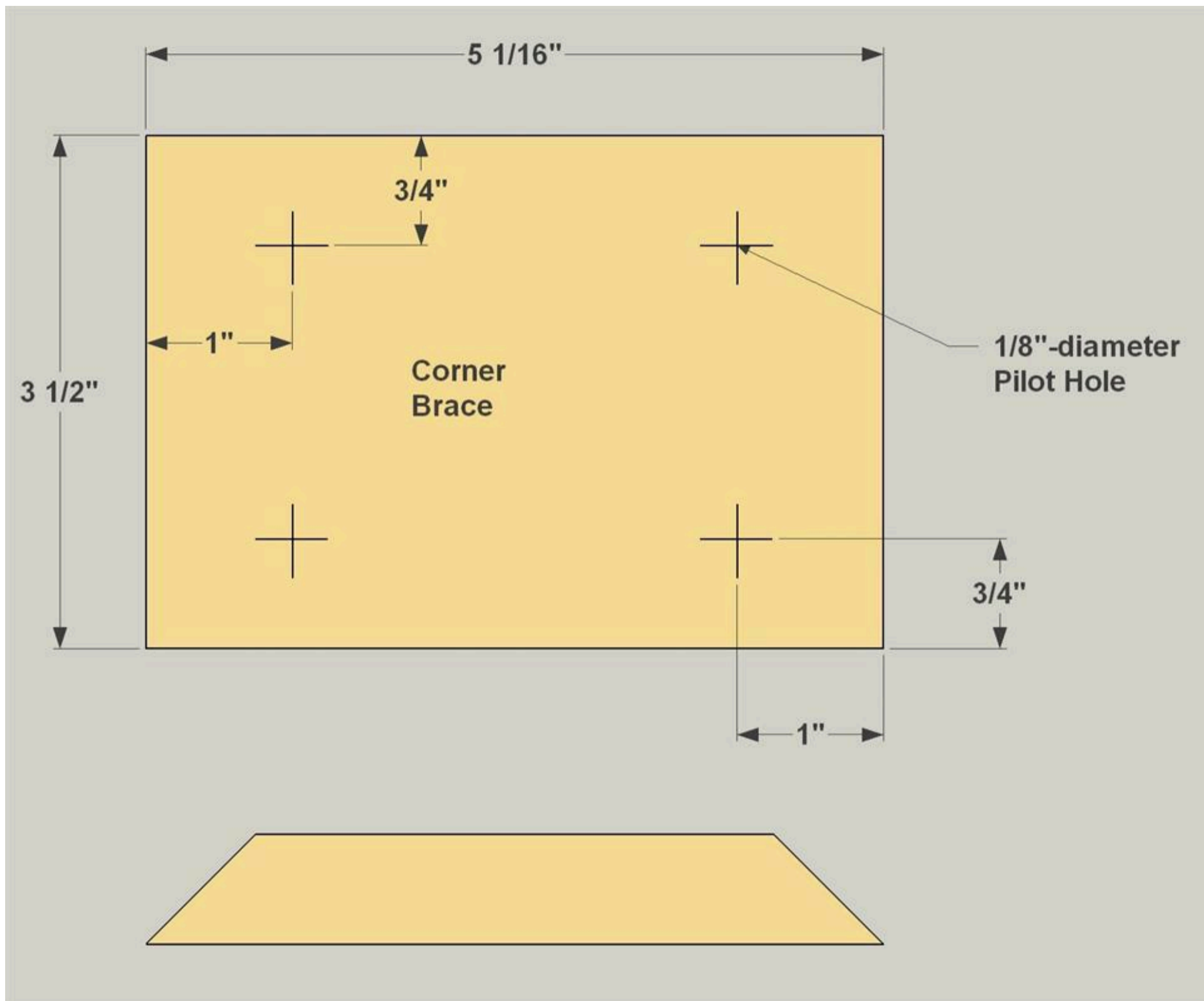

6**Secure the Corner Braces**

Now you can wrap up the base by attaching the Corner Braces. You can use 1 1/2" fine-thread pocket hole screws for this, even though you're not driving them into pocket holes. Just hold the Brace in place, and then drive the screws into the Rails.

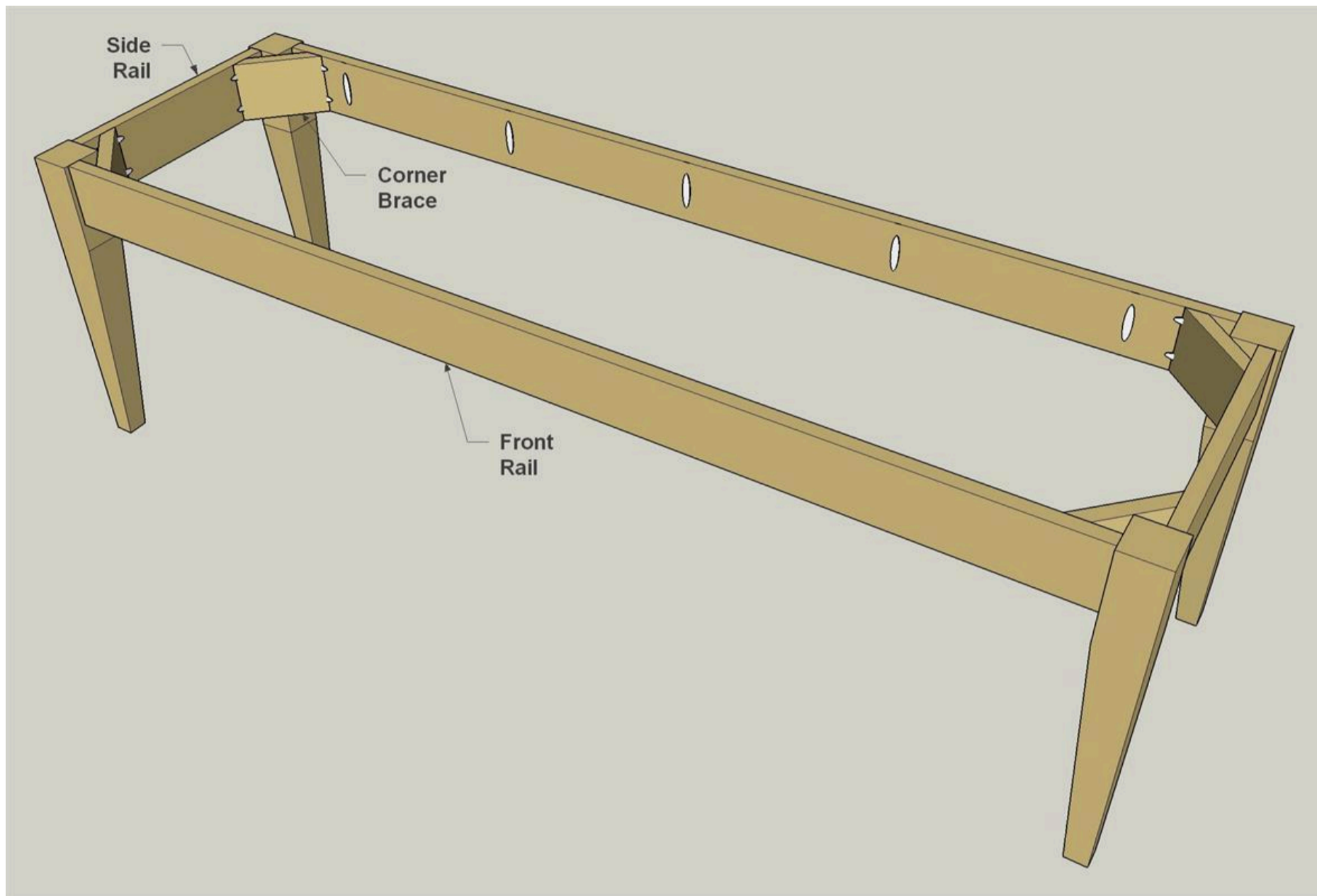

7

Start Cutting Case Parts

Cut a Case Top, a Case Bottom, two Case Sides, two Case Dividers, and a Case Shelf to size from 3/4" plywood, as shown in the cutting diagram. Then drill pocket holes in the Case Top, Case Bottom, Dividers, and Shelf, as shown, with your pocket hole jig set up for 3/4" material.

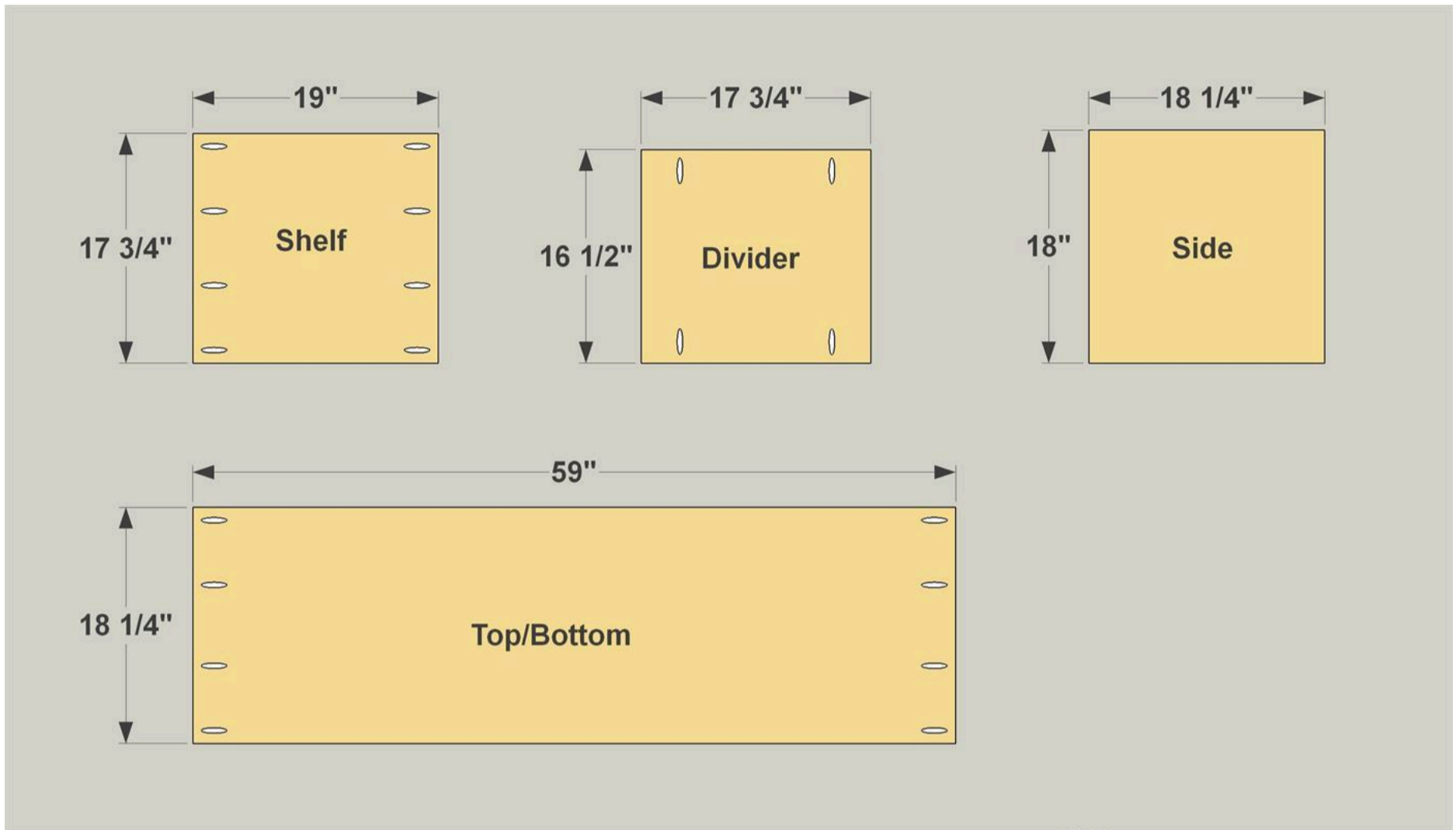

8

Add a Case Back

Cut a Case Back to size from 1/2" plywood, as shown in the cutting diagram. Then, with your pocket hole jig set up for 1/2" material, drill pocket holes in the Back, as shown.

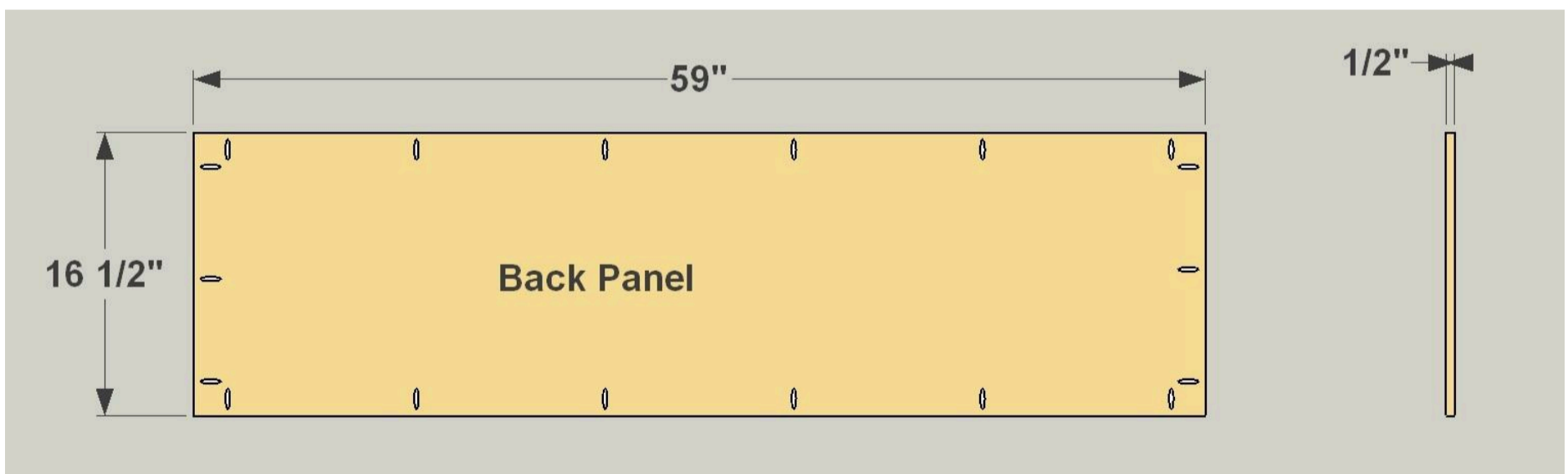

9**Start Case Assembly**

Before you begin assembling the case, you'll need to hide the exposed plies on the front edges of the Top, Bottom, Sides, Dividers, and Shelf. To cover them, apply iron-on edge banding. Then attach the Case Sides, Dividers, and Shelf using 1 1/4" coarse-thread pocket hole screws, as shown. Note that the Dividers sit flush with the front edge of the Case Bottom.

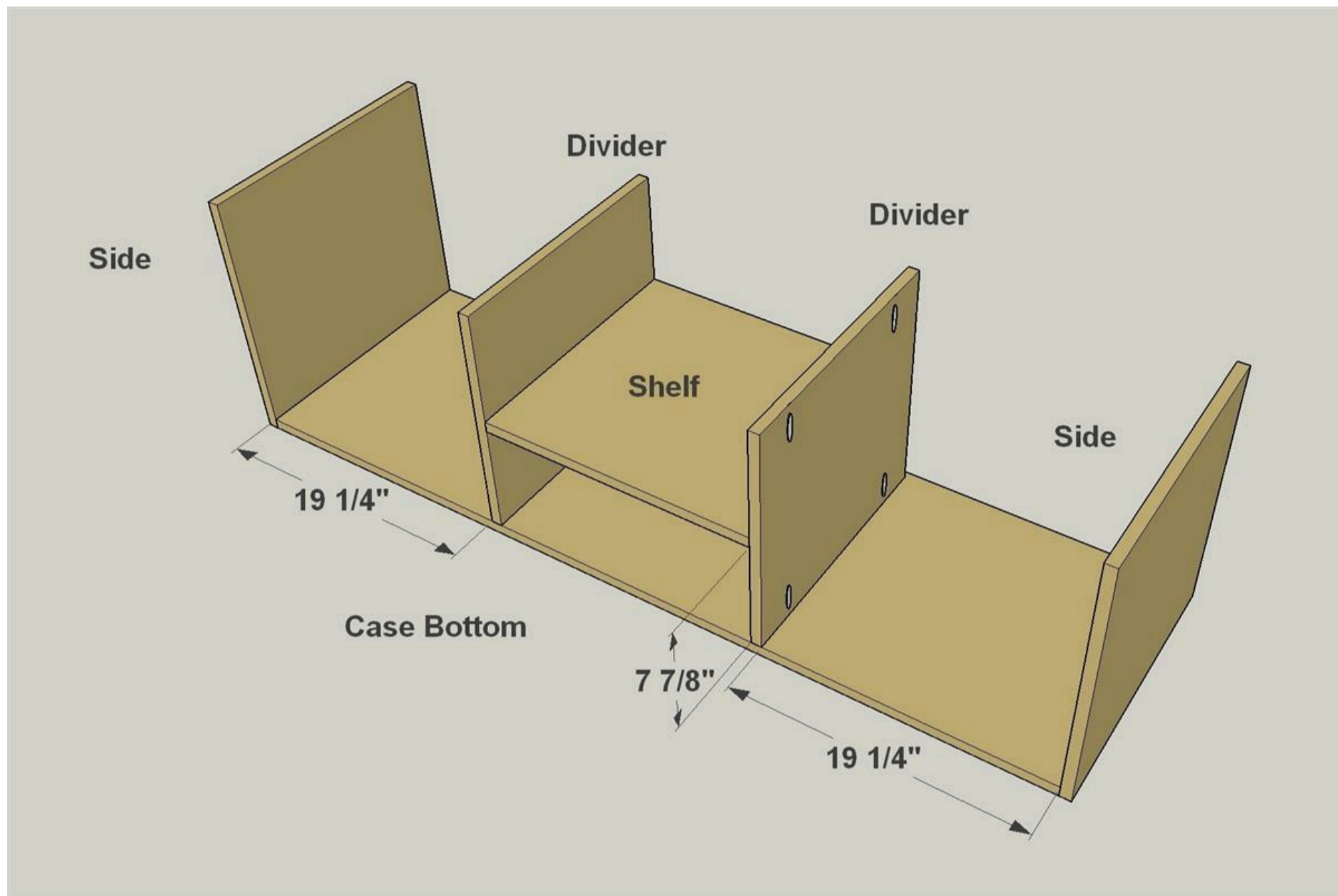

10

Bring on the Top and Back

Next, add the Top using 1 1/4" coarse-thread pocket hole screws. Then slip the Back into place and attach it using 1 1/4" coarse-thread pocket hole screws.

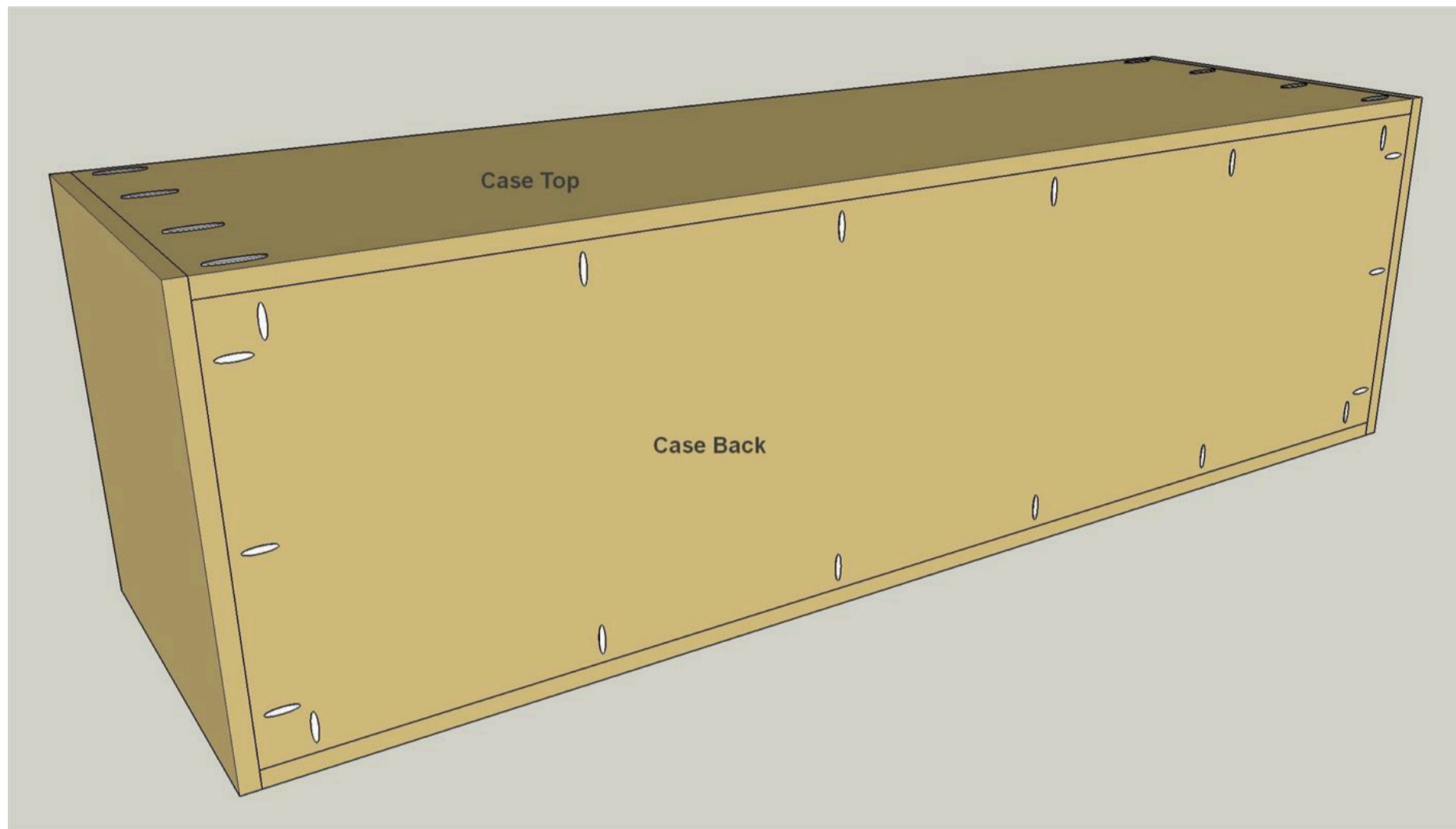

11

Cut a Top to Size

Cut a Top to size from 3/4" plywood, as shown in the cutting diagram. Then, with your pocket hole jig set up for 3/4" material, drill pocket holes in the Top as shown.

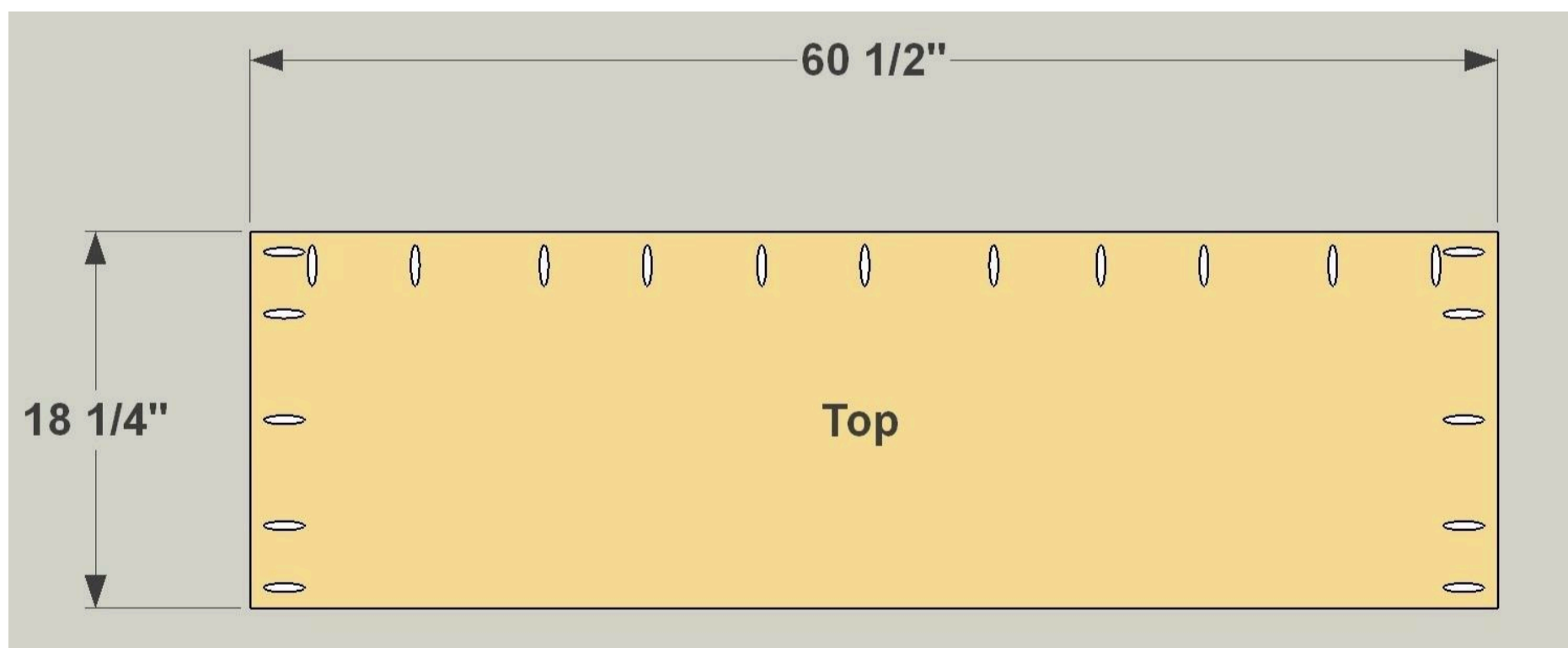

12

Trim Out the Top

Cut one piece of Top Front Edge to length from a 1x2 board, mitering both ends at 45°. Then cut two Top Side Edge pieces, cutting one end at 45°, and the other end square. Then you can attach them to the Top using glue and 1 1/4" coarse-thread pocket hole screws. Glue the mitered ends of the Edge pieces together as you attach them.

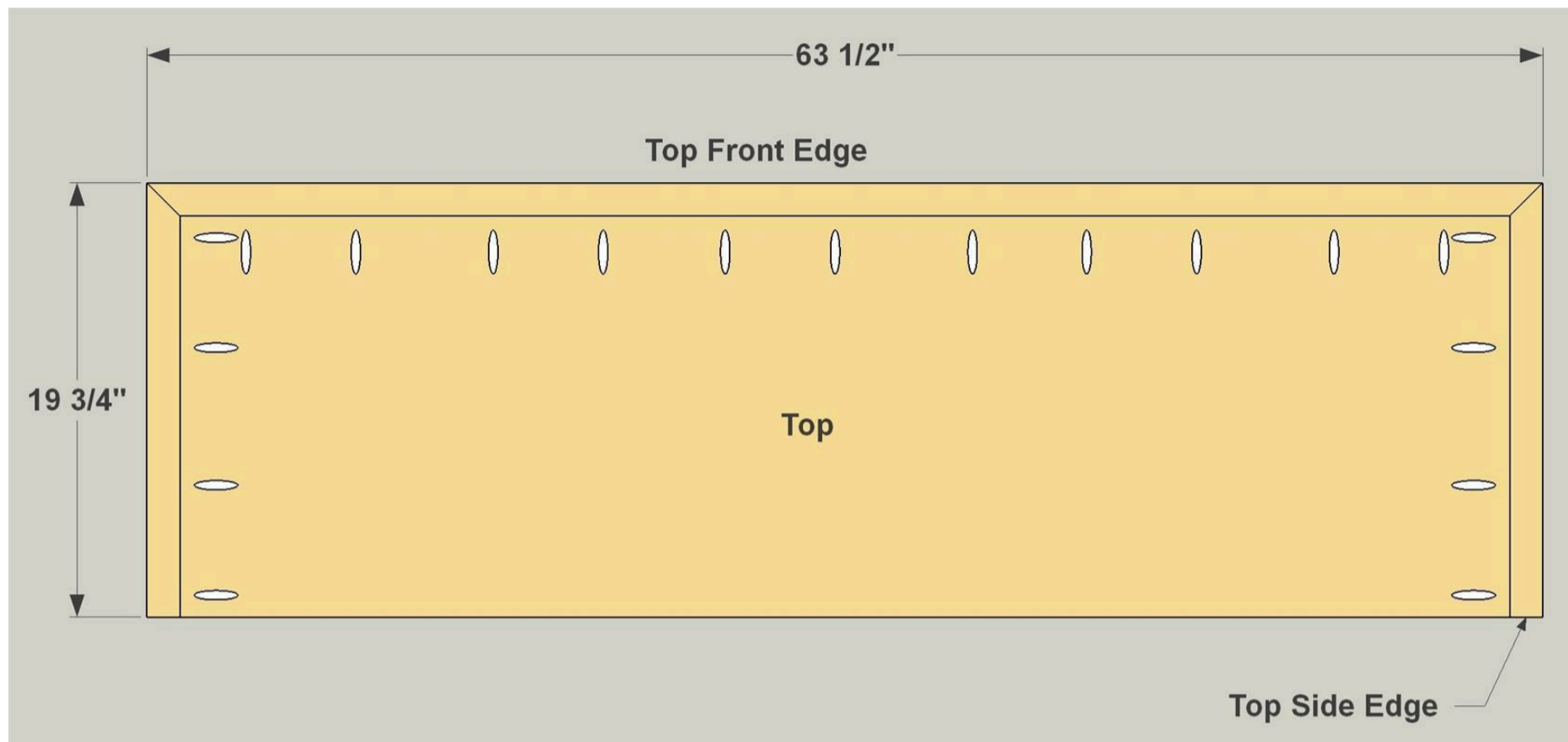

13

Make Door Panels

If you want to add doors to your sideboard, start by cutting two Door Panels to size from 1/2" plywood. Then, with your pocket hole jig set for 1/2" material, drill pocket holes in the Door Panels.

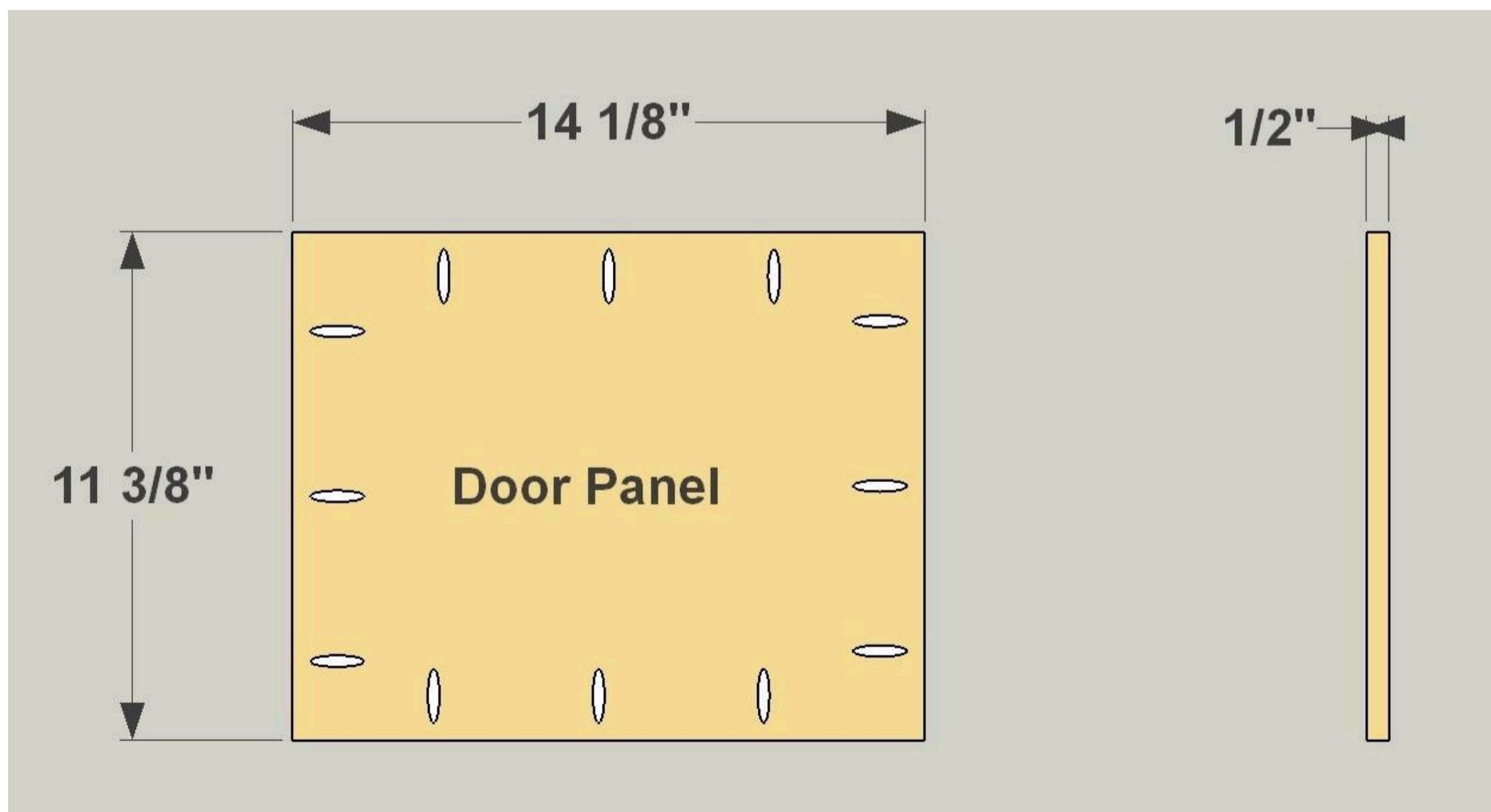

14**Door Rails and Stiles Come Next**

Cut four Door Stiles and four Door Rails to length from 1x3 boards, as shown in the cutting diagram. Then, with your pocket hole jig set for 3/4" material, drill pocket holes in the Door Rails.

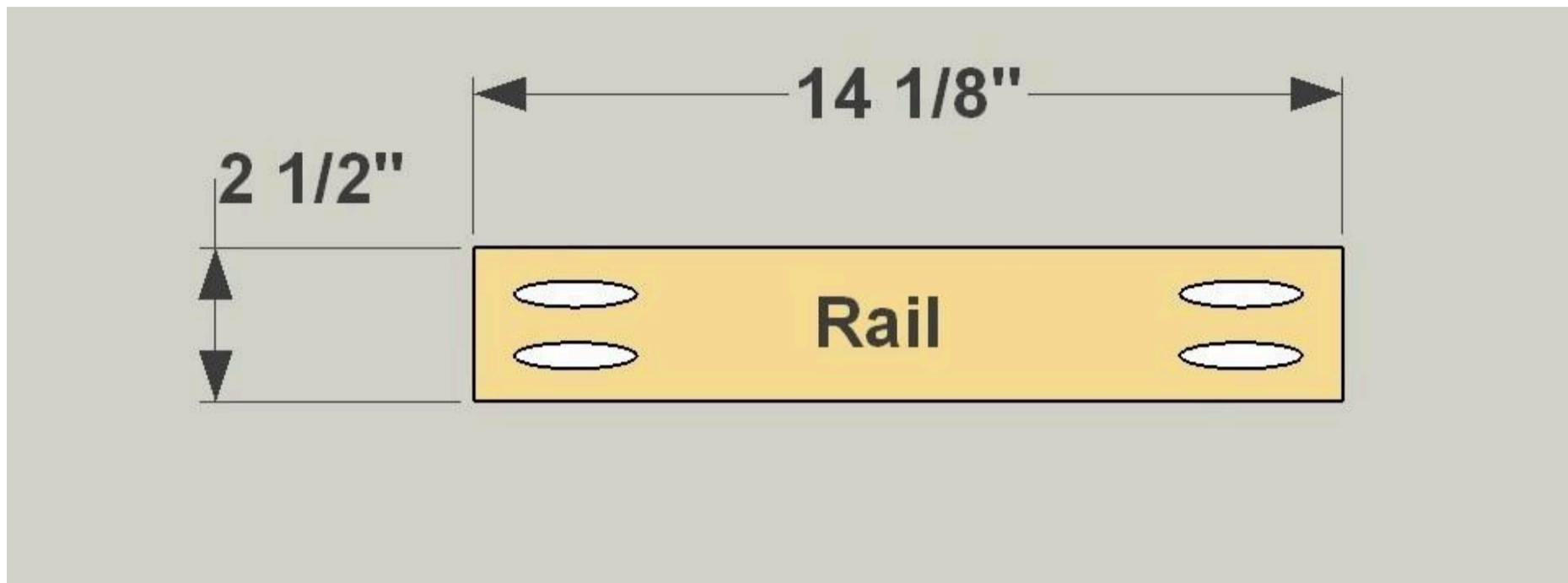

15**Assemble the Doors**

To assemble the doors, start by attaching the Rails to the Stiles using 1 1/4" fine-thread pocket hole screws. Then slip the Door Panels into place, and attach them with 1 1/4" fine-thread pocket hole screws, as well. Then mount hinges and position the completed doors in the case. You can also drill holes for knobs and install those on the doors, as well as door catches, if you wish.

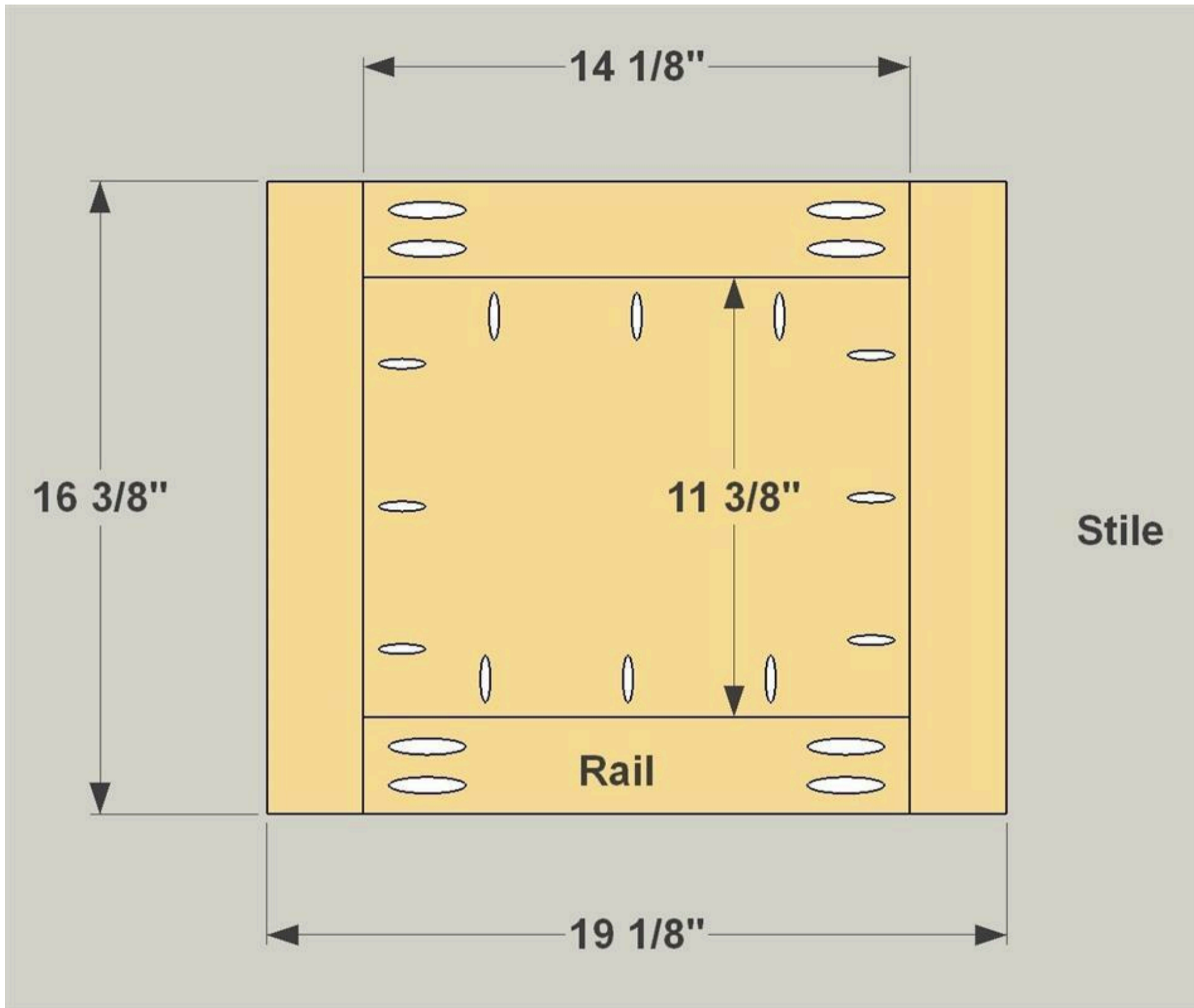

16**Put it All Together**

With the subassemblies done, you can put them all together. Start by mounting the case to the base using 1 1/4" coarse-thread pocket hole screws. Then position the top, and attach it by driving 1 1/4" fine-thread pocket hole screws up from underneath. Place four screws through the inside the compartments that are covered by doors.

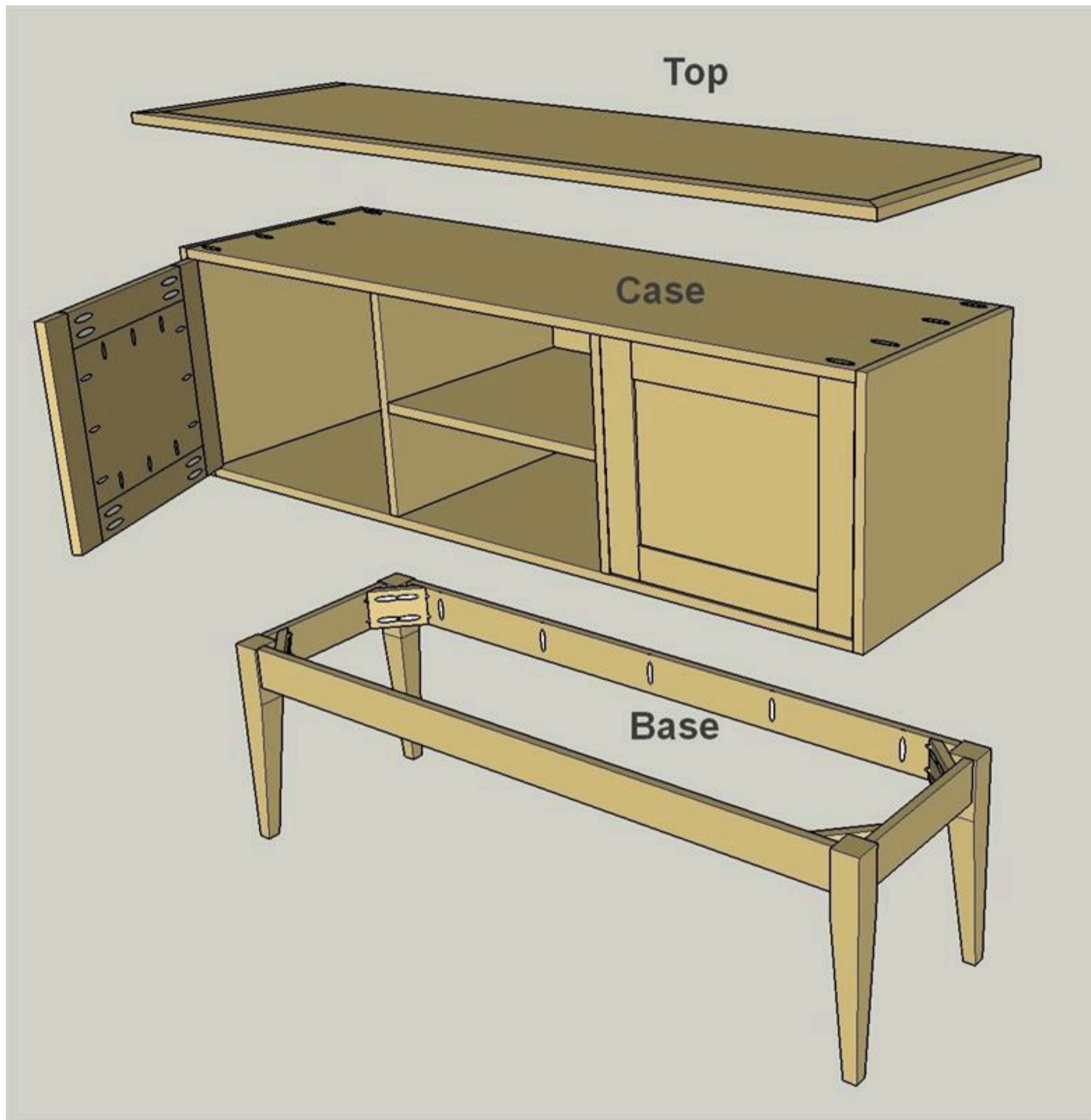
**17****Stain to Suit**

All that's left to do is stain, finish, or paint the sideboard. Remove the door hardware when you do this, and then reinstall it after everything dries.