

Wall Mounted Wine Bar

By **Scott @ Saws on Skates**

Difficulty
Moderate

This wall mounted wine bar is a stylish space-saving storage solution for wine bottles and wine glasses. It can also serve as an attractive display option for liquor and bar accessories.

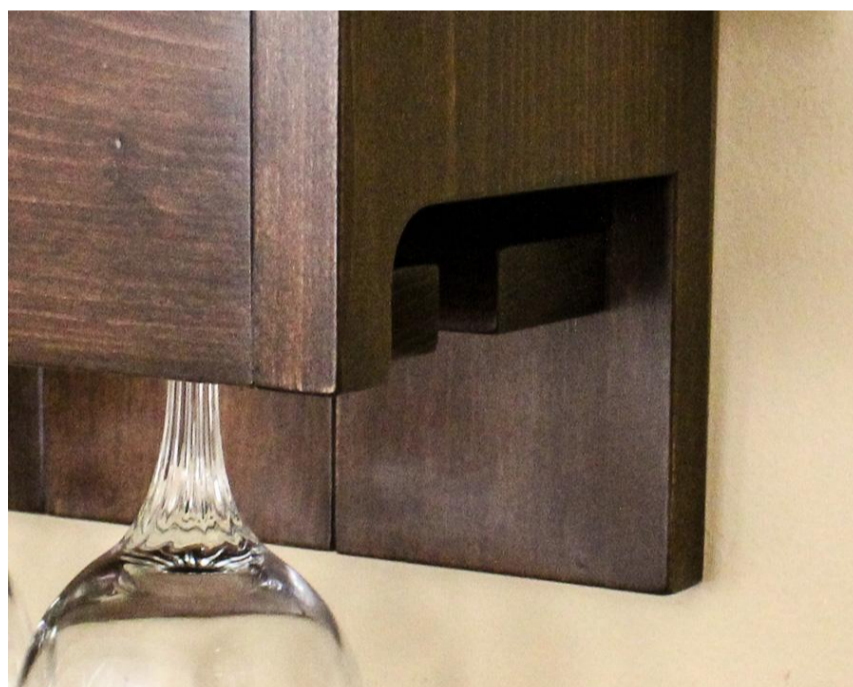
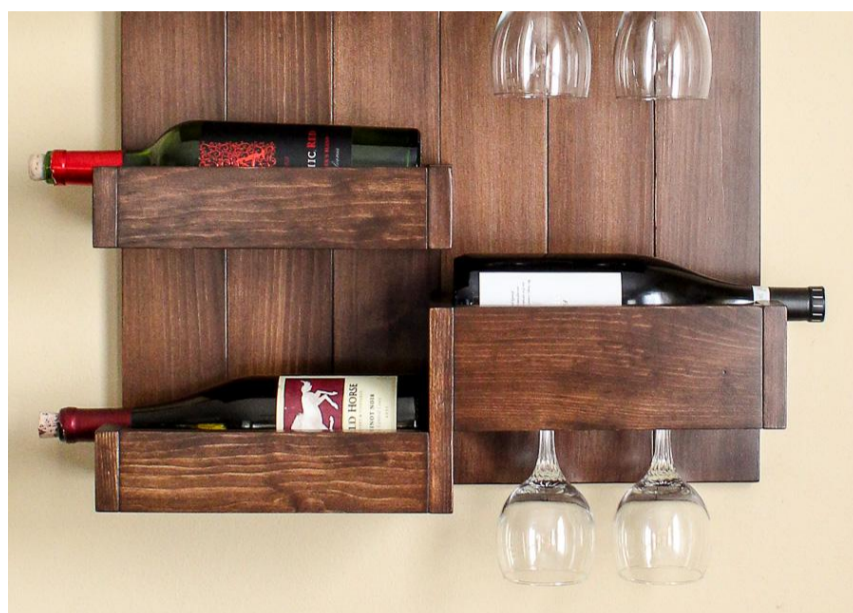

Tools

Kreg Tools



[Kreg® Pocket-Hole Jig 720](#)

Other Tools

Jigsaw

Miter Saw

Square

Table Saw

Tape Measure

Clamps

Drill (cordless)

Sander

Materials

Wood Products

2 Board , 1x4 , 96"

1 Board , 1x8 , 72"

1 Board , 1x3 , 96"

1 Board , 1x5 , 96"

Hardware & Supplies

40 1-1/4" Pocket Screws

18 1-1/4" Wood Screws

4 2-1/2" Wood Screws

1 Wood Glue

1 Sandpaper

1 Walnut Wood Stain

1 Polyurethane

1 Hanger

Cut List & Parts

- 6 Back , 3/4" X 3-1/2" X 22-3/4"
- 2 Middle Upright , 3/4" X 5-5/8" X 6-1/4"
- 3 Bottle Holder Front , 3/4" X 2-1/2" X 9-3/8"
- 4 Bottle Holder Side , 3/4" X 2-1/2" X 5-5/8"
- 5 Bottle Holder Bottom , 3/4" X 4-1/2" X 9-3/8"
- 2 Bottle/Glass Holder Side , 3/4" X 3-3/4" X 5-5/8"
- 2 Bottle/Glass Holder Front , 3/4" X 3-3/4" X 9-3/8"
- 4 Glass Holder , 3/4" X 1-7/8" X 9-3/8"

Directions

1

Make the Back

Cut 6 pieces of 1x4 to 22-3/4". Drill pocket holes, apply glue to the edges, clamp and attach using 1-1/4" pocket screws.

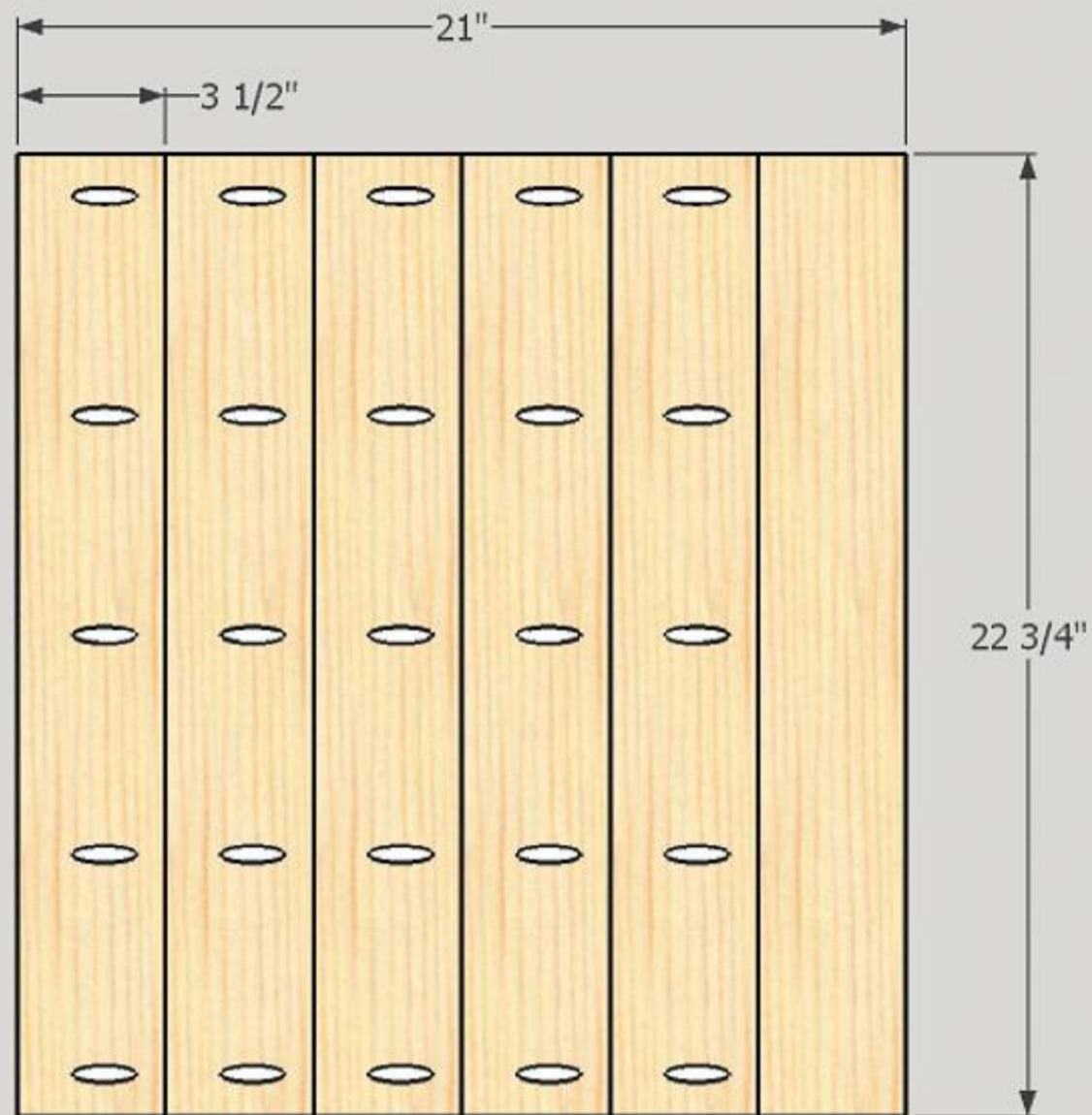

2

Cut Bottle Holder Middle Upright

Cut 2 pieces of 1x8 to 6-1/4" and rip to 5-5/8".

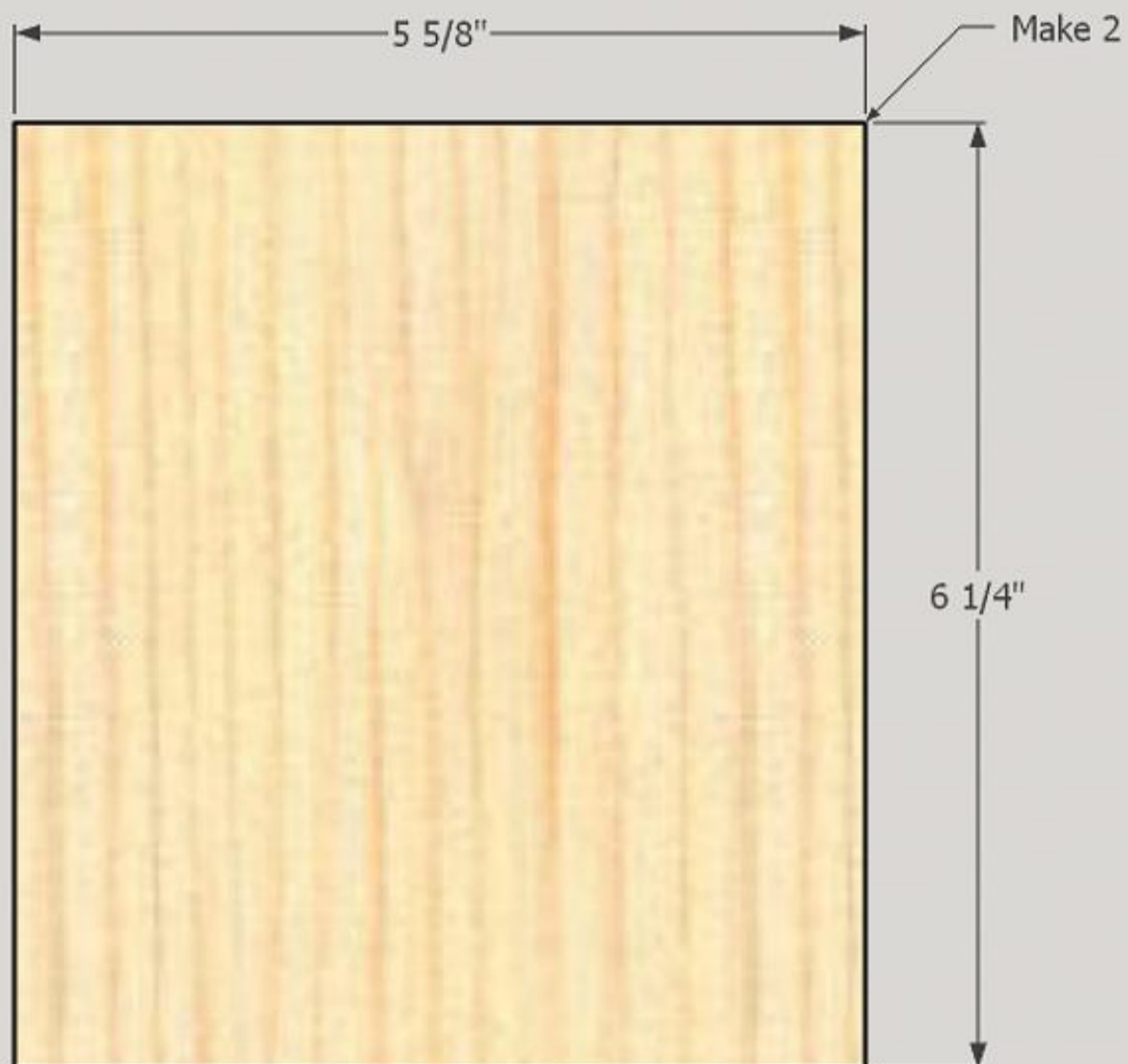

3**Cut the Bottle Holder Front**

Cut 3 pieces of 1x3 to 9-3/8" and drill pocket holes in each end. 2 pieces will be used for the top and bottom bottle holders and 1 piece will be used for the middle bottle holder.

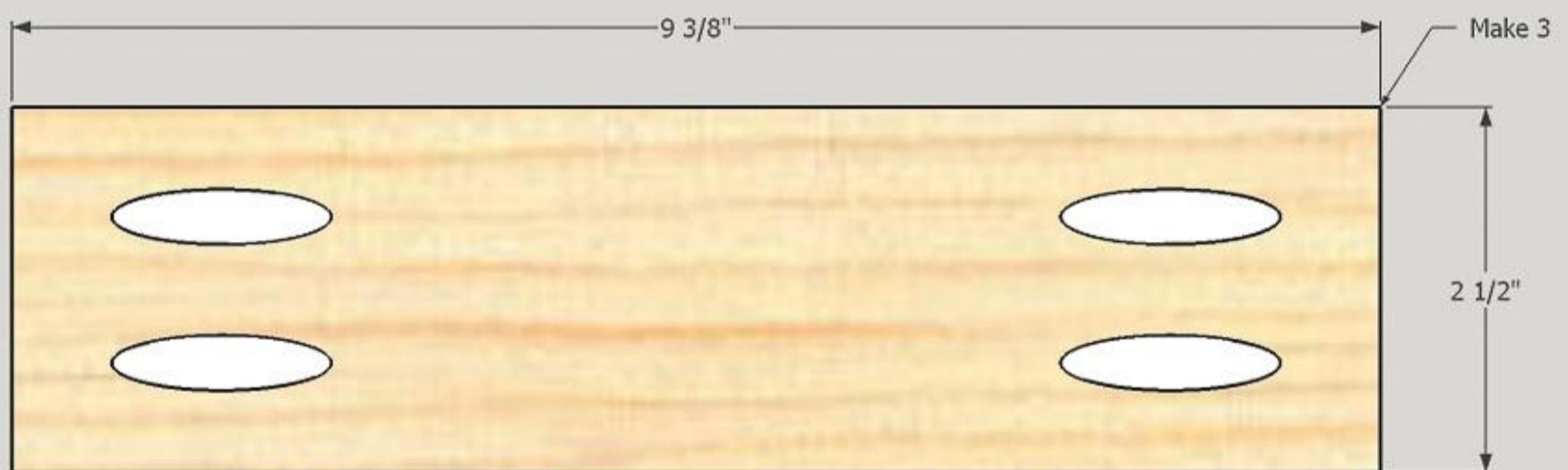

4**Cut the Bottle Holder Side**

Cut 4 pieces of 1x8 to 2-1/2" and rip to 5-5/8". In 3 of the pieces, you will drill a hole and these pieces will be used as the left side of the top, bottom and middle bottle holders. 1 piece will remain solid (no hole) and will be used in Step 13 as the right side of the middle bottle holder. Measure in 2-13/16" and make a mark. Temporarily clamp a piece of scrap wood and use a 1-1/2" diameter Forstner bit to drill a hole.

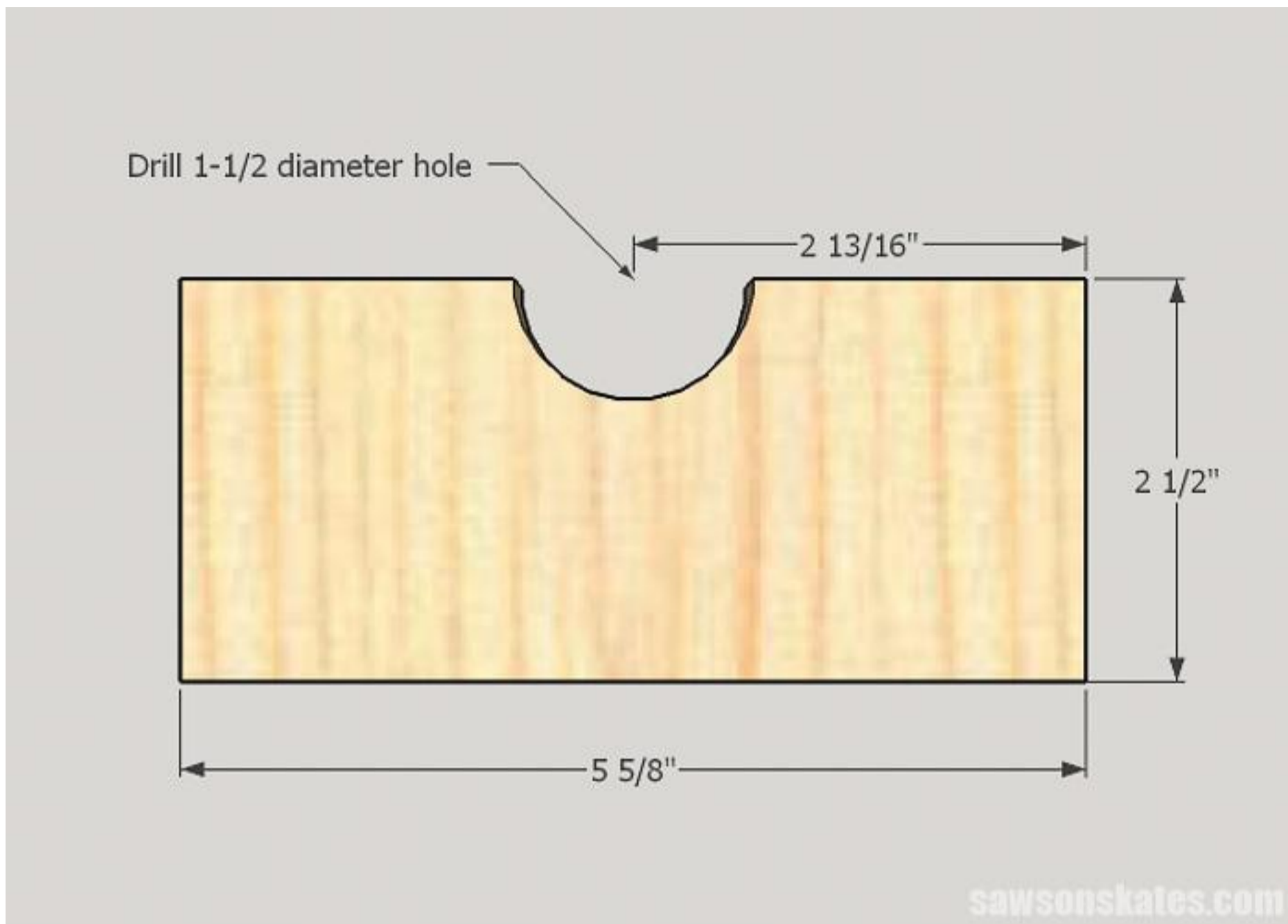

5

Assemble Top/Bottom Bottle Holders

Apply glue to ends of the front, clamp to the sides and attach using 1-1/4" pocket screws. Repeat for the other bottle holder assembly.

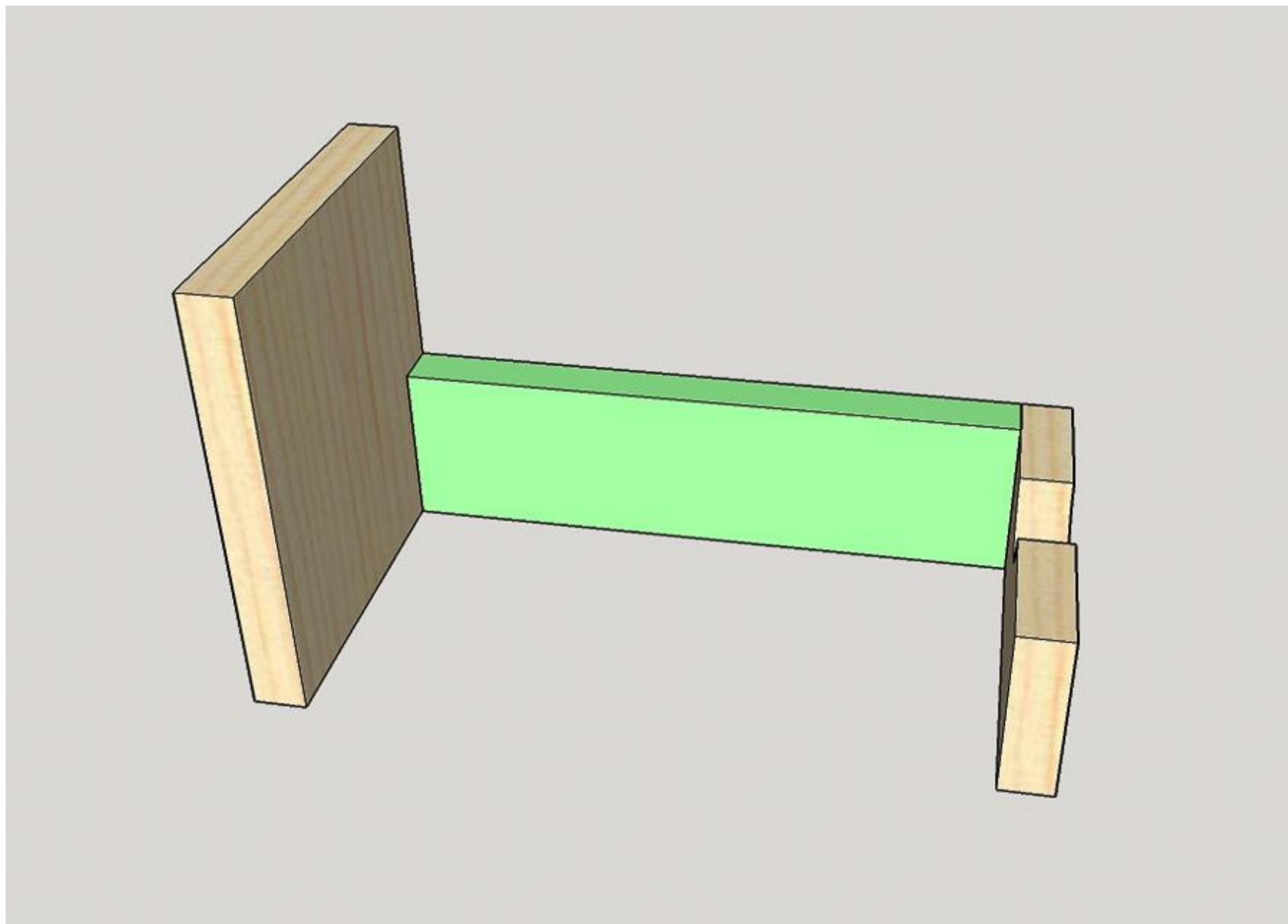

6**Attach the Bottle Holder Bottom**

Cut 5 pieces of 1x5 to 9-3/8" and drill pocket holes in each end. 2 will be used in this step for the top and bottom bottle holders. 2 will be used in Step 9 for the bottle/glass holders and 1 will be used in Step 14 for the middle bottle holder.

Center the bottom on the sides, clamp in position and attach using 1-1/4" pocket screws. Repeat for the other bottle holder assembly.

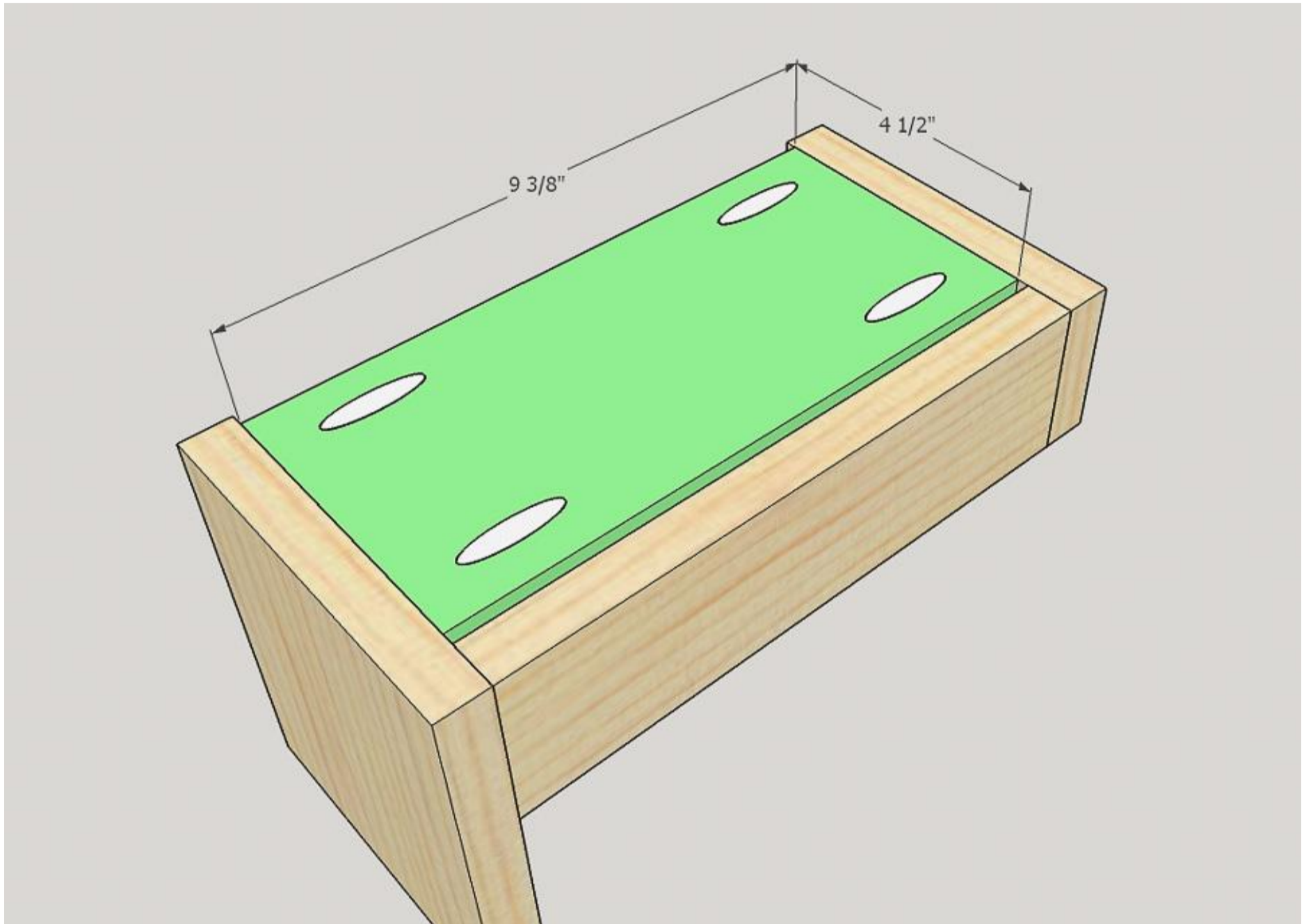

7**Cut the Bottle/Glass Holder Side**

Cut 2 pieces of 1x8 to 3-7/8" and rip to 5-5/8". Measure in 2-13/16" and make a mark. Temporarily clamp a piece of scrap wood and use a 1-1/2" diameter Forstner bit to drill a hole. On the bottom measure up 7/8" and in 1-1/4" and make a mark. Using a 1" Forstner bit drill a hole at the mark. Use a jigsaw or bandsaw remove the remaining wood and form the opening for the wine glasses.

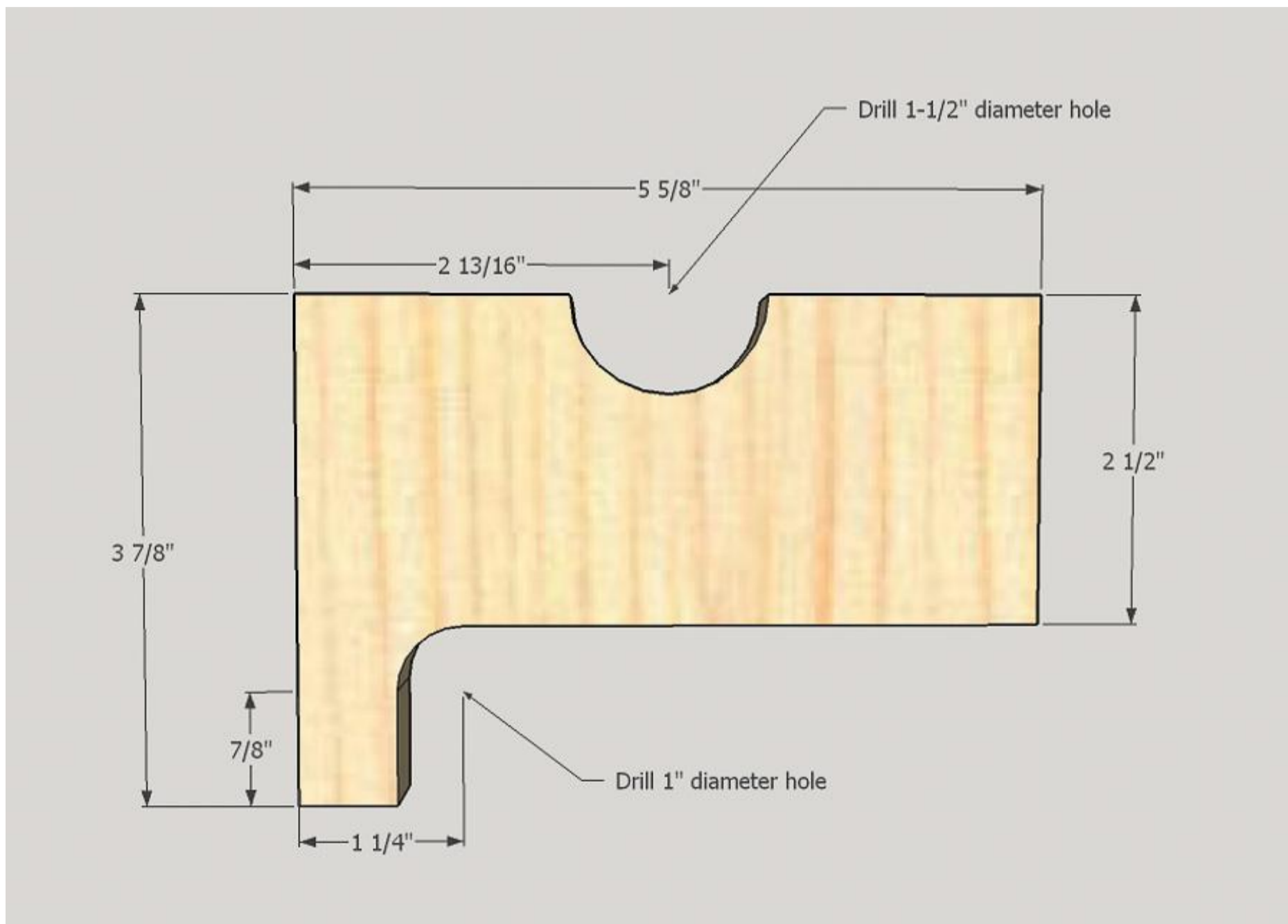

8**Assemble the Bottle/Glass Holders**

Cut 2 pieces of 1x5 to 9-3/8" and rip to 3-7/8". Drill pocket holes in each end. Clamp the front to the sides and attach using 1-1/4" pocket screws. Repeat for the other bottle/glass holder assembly.

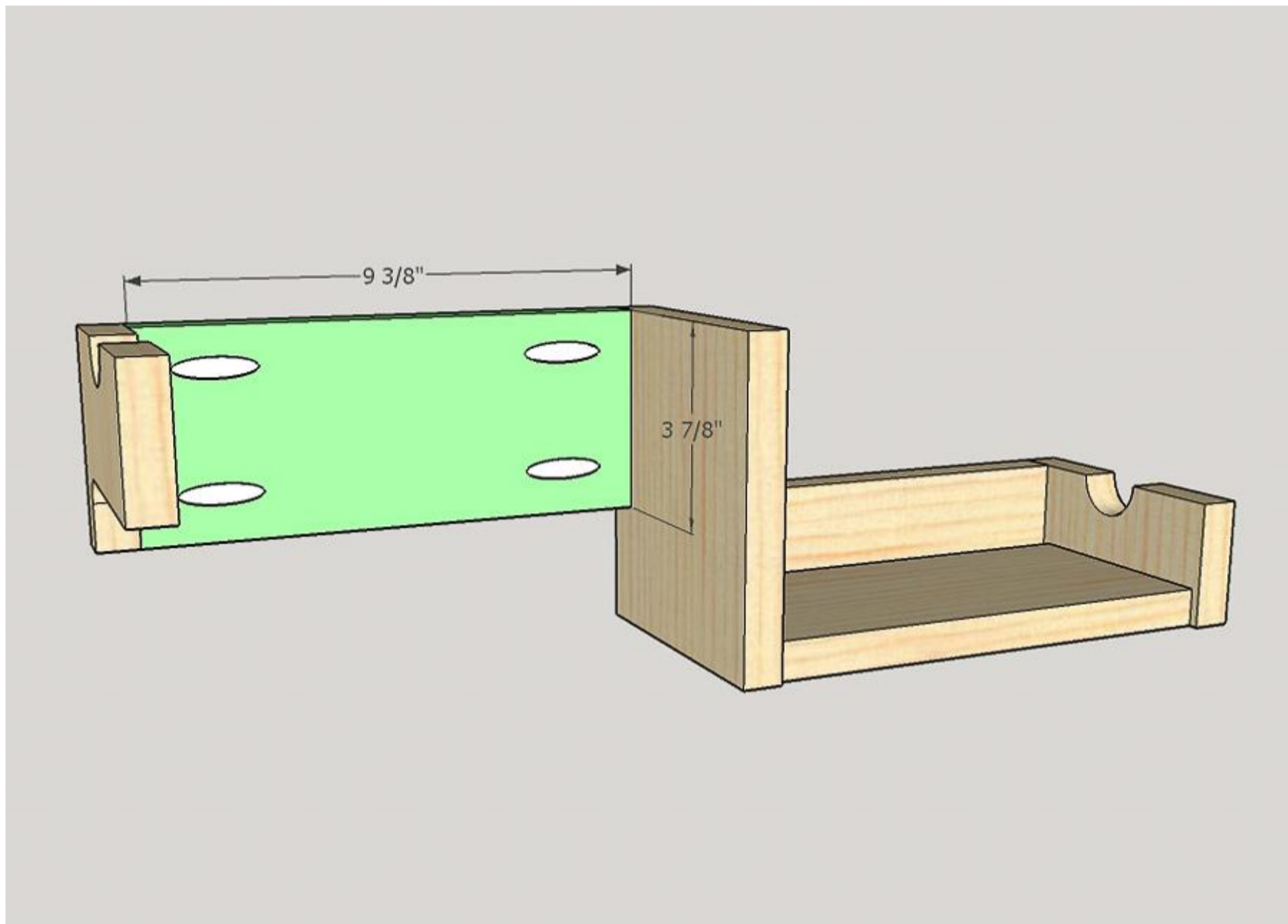

9

Attach Bottle/Glass Holder Bottom

Center the bottom on the sides, clamp in position and attach using 1-1/4" pocket screws. Repeat for the other bottle/glass holder assembly.

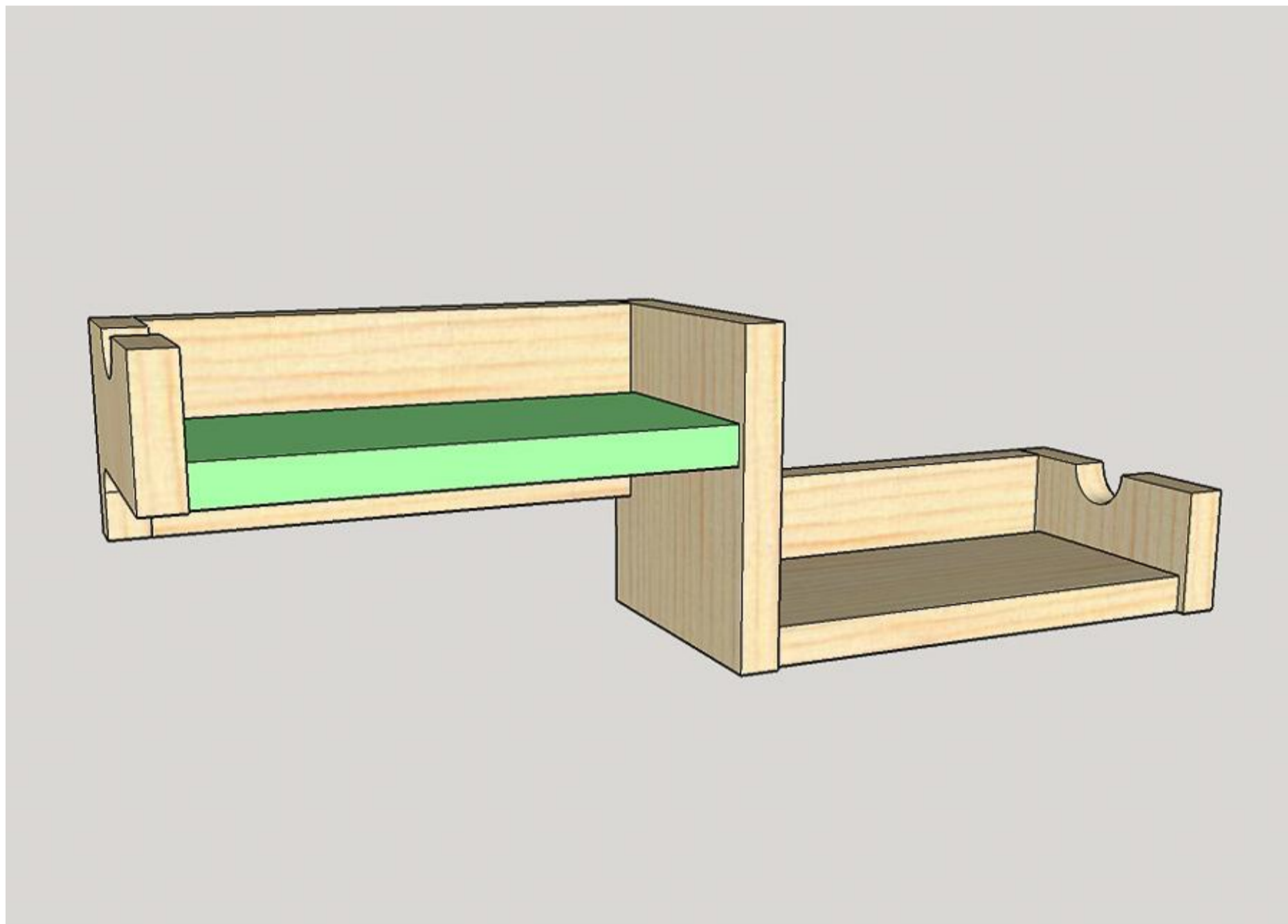

10**Cut and Install the Glass Holders**

Cut 4 pieces of 1x3 to 9-3/8" and rip to 1-7/8". Drill countersink holes in the edges of the pieces. 2 of the holders will be used in this step and 2 will be used in the next step. Place a holder at the bottom of the bottle/glass holder, clamp and attach using 2-1/2" wood screws. Repeat for the other bottle/glass holder assembly.

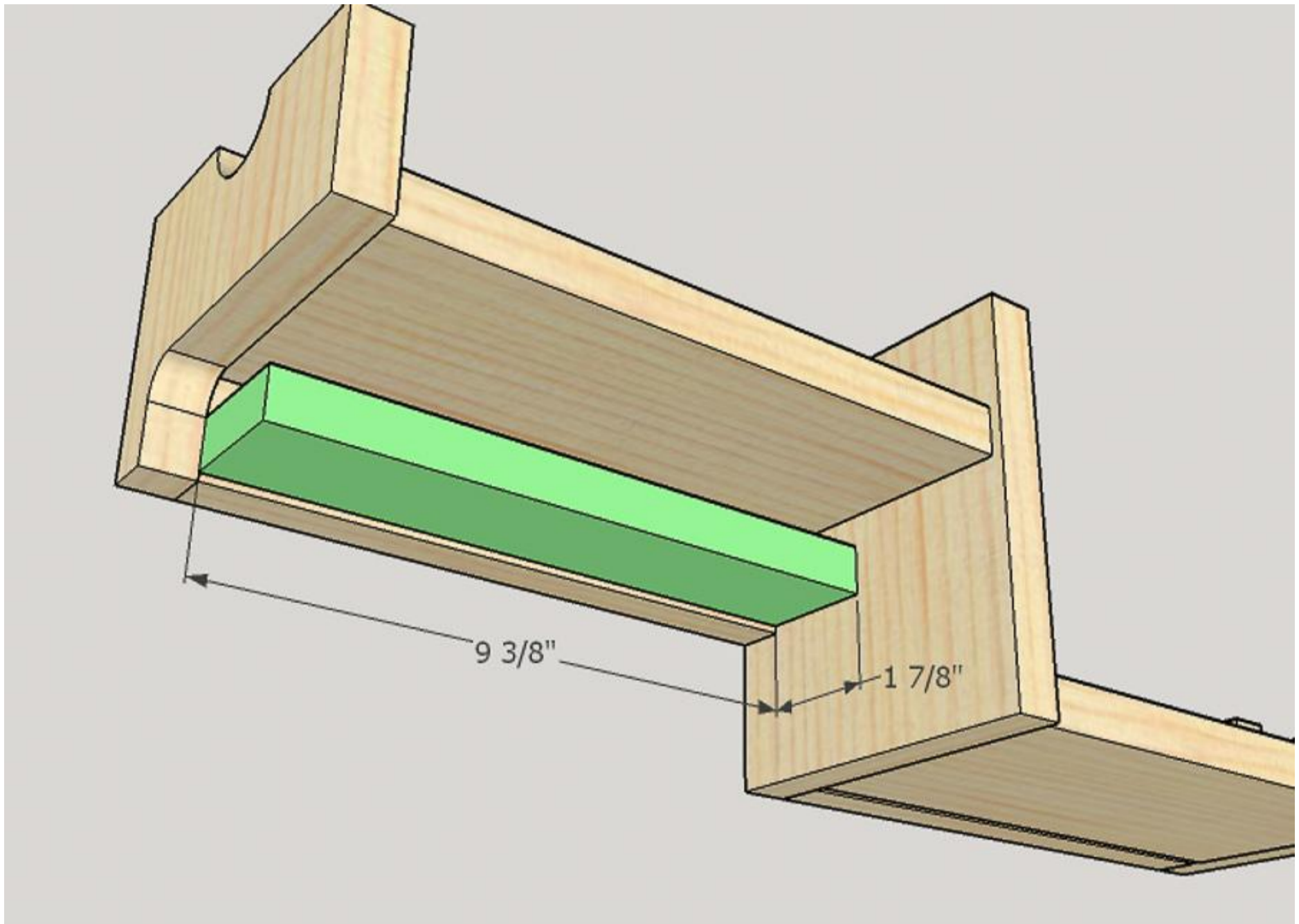

11**Install the Remaining Glass Holders**

Temporarily place the bottle holder assemblies on the back and clamp. The bottom assembly is flush with the bottom. The right side of the top assembly sets down a 1/2" from the top. Use a speed square to place the remaining glass holders so they are flush with the front glass holders. Remove the bottle holder assemblies and attach the glass holders to the back using 2-1/2" wood screws.



12

Attach the Top/Bottom Assemblies

Place the holder assemblies on the back. The bottom assembly is flush with the bottom. The right side of the top assembly sets down a 1/2" from the top. Lightly trace the sides and middle uprights onto the back with a pencil. From the front drill holes within the pencil lines. From the back use the holes you just drilled as pilot holes to drill countersink holes into the assemblies. Attach the assemblies using 1-1/4" wood screws.



13

Assemble the Middle Bottle Holder

Clamp the front to the sides and attach using 1-1/4" pocket screws.

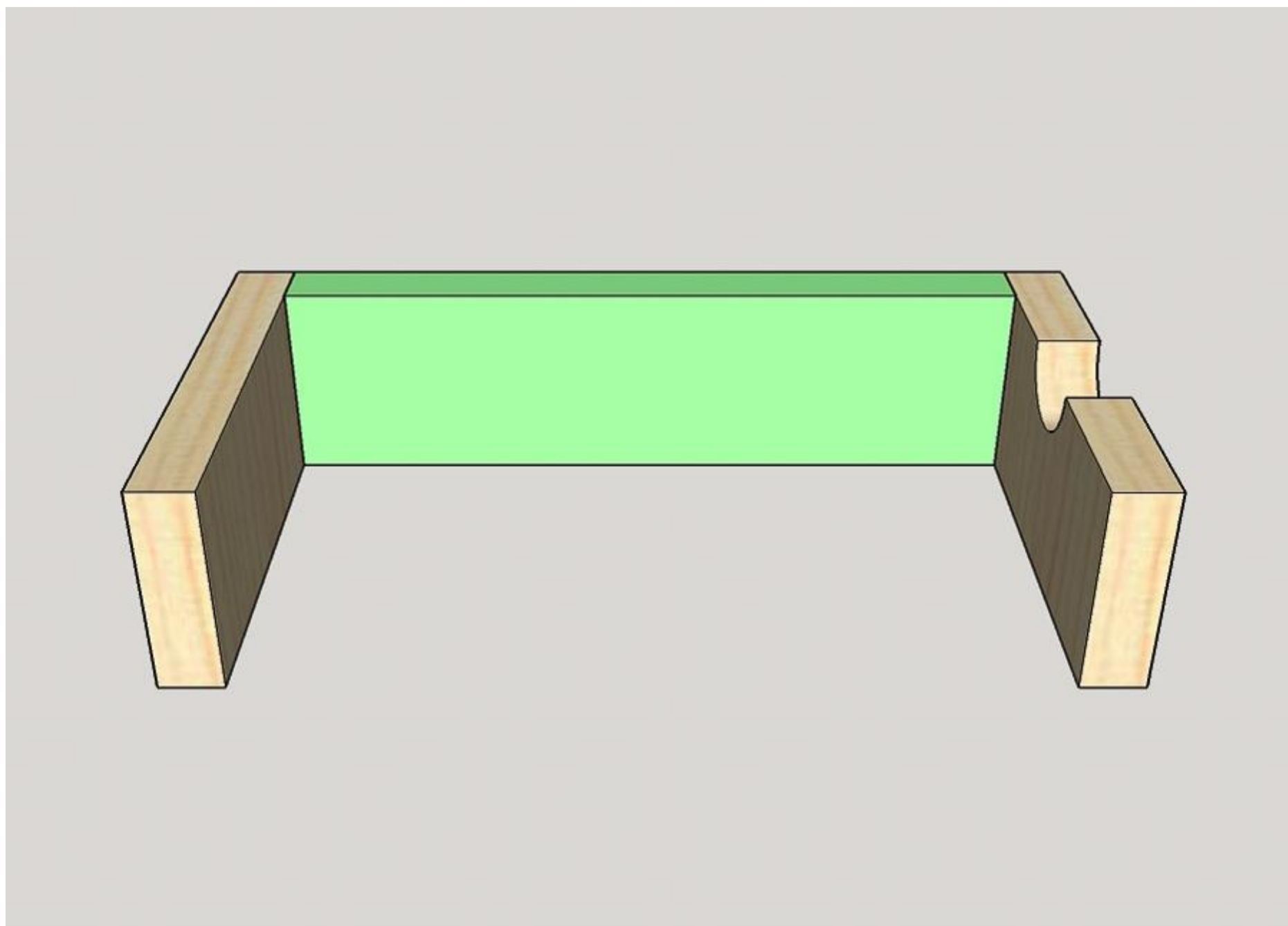

14

Attach Middle Bottle Holder Bottom

Center the bottom on the sides, clamp in position and attach using 1-1/4" pocket screws.

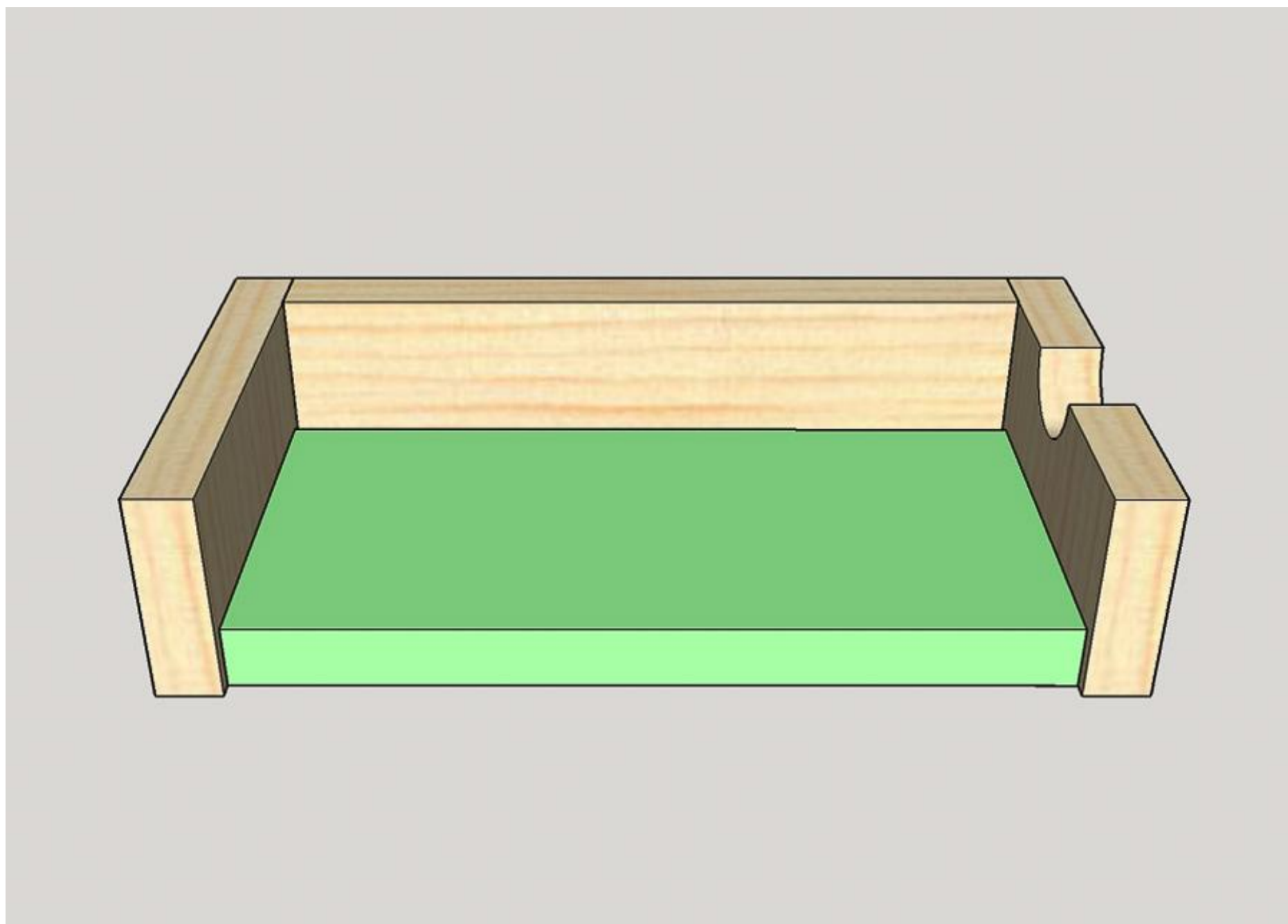

15

Attach Middle Holder Assembly

Place the middle bottle holder on the back. The holder sets up 8" from the bottom. Lightly trace the sides with a pencil onto the back. From the front drill holes within the pencil lines. From the back use the holes you just drilled as pilot holes to drill countersink holes into the holder. Attach using 1-1/4" wood screws.

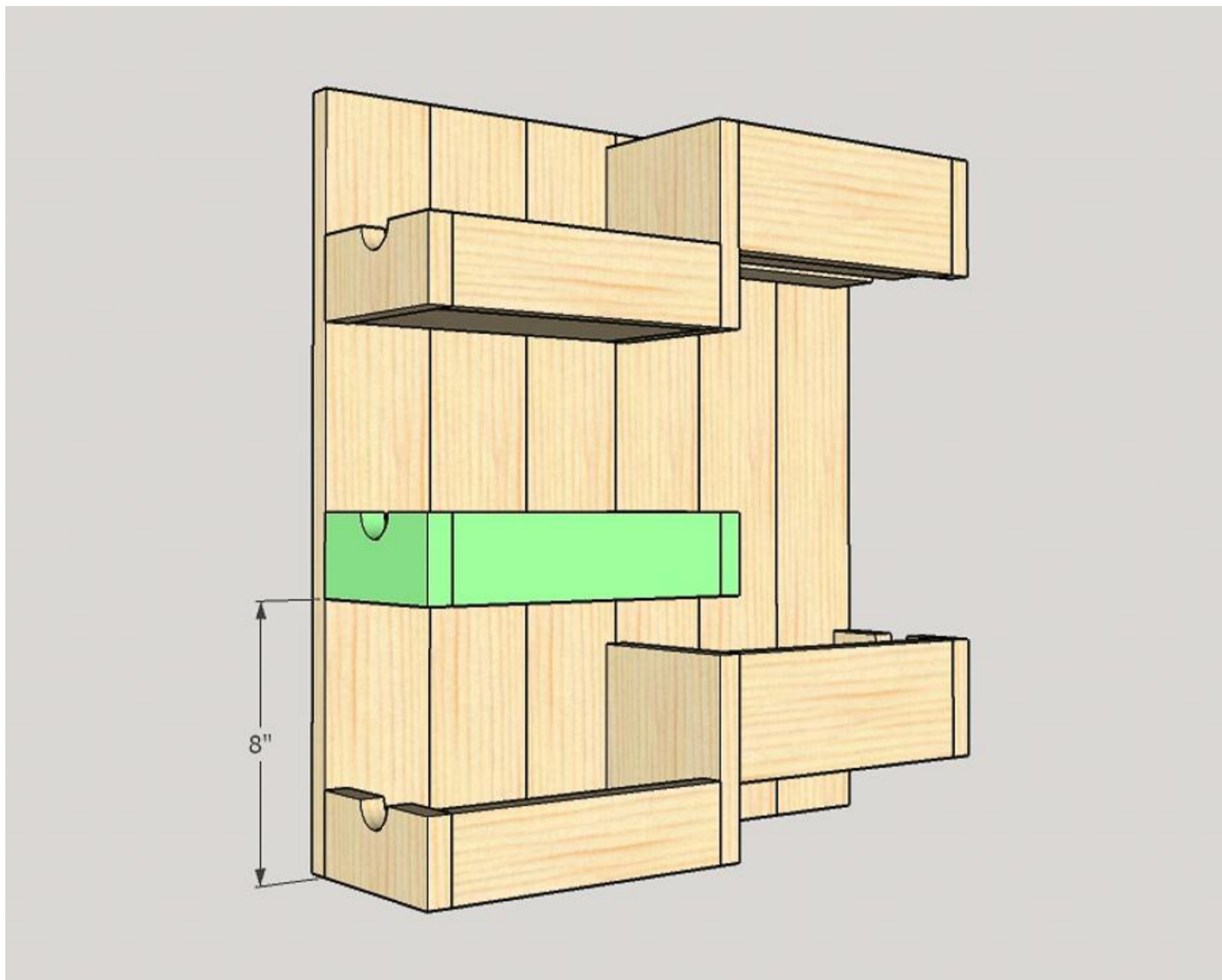

16

Attach the Hanger

Attach the hanger according to the manufacturer's instructions.



17

Sand, Stain, and Finish

It's easiest to disassemble the wine bar, then stain, and finish. Please head over to [Saws on Skates](#) for useful finishing tips and tricks.