

Rolling Kitchen Island

By **Reality Daydream**

Difficulty

Moderate

Sturdy rolling kitchen island with butcher block top and place for microwave and garbage/trash can!

Come on over to our blog for the full post and more reveal pics! >> <http://realitydaydream.com/2016/02/custom-diy-rolling-kitchen-island.html>

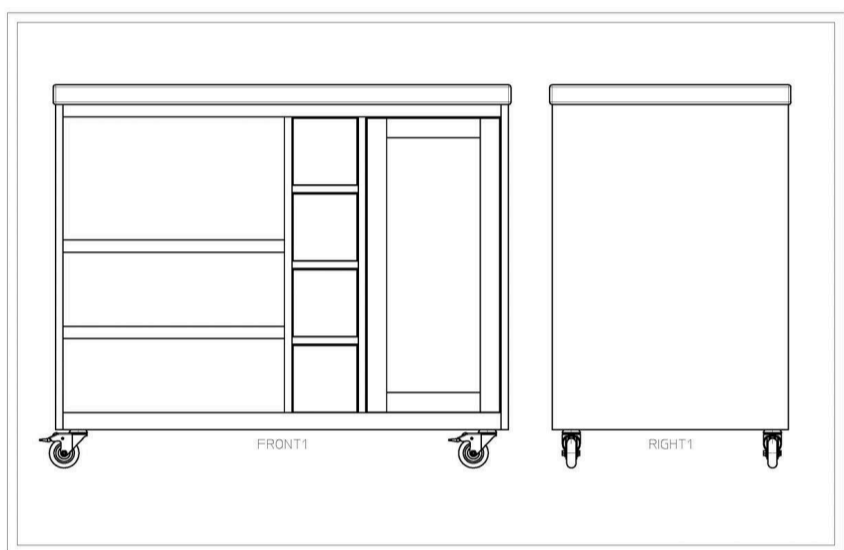



Tools

Kreg Tools



[Kreg@ Pocket-Hole Jig 720](#)



[Kreg@ Pocket-Hole Jig 720](#)

Other Tools

Miter Saw

Square

Table Saw

Tape Measure

Thickness Planer

Clamps

Drill (cordless)

Nail Gun

Router Table

Shop Vacuum

Materials

Wood Products

2 Plywood , 3/4" Thick , Full Sheet

1 Plywood , 1/2" Thick , Half Sheet

1 Plywood , 1/4" Thick , Half Sheet

1 Board , 1x8 , 96"

Hardware & Supplies

2 Hickory Hardware

4 3" Swivel Caster

1 18" Towel Bar

60 1 1/4" Fine Thread Kreg Screws

75 1 1/2" #2 SQ Dr Pan Head Kreg Screws

Cut List & Parts

- 2 Panel A & Panel B , 3/4" X 4' X 8'
- 1 TOP, ROLLING ISLAND , 2" X 24 1/2" X 46 1/2"
- 2 SIDES, ROLLING ISLAND , 3/4" X 33" X 24"
- 2 VERTICAL DIVIDERS, ROLLING ISLAND , 3/4" X 31 1/4" X 24"
- 1 BOTTOM, ROLLING ISLAND , 3/4" X 44 1/2" X 22 1/2"
- 2 TOP RAIL, ROLLING ISLAND , 3/4" X 44 1/2" X 1 1/4"
- 2 BOTTOM RAIL, ROLLING ISLAND , 3/4" X 44 1/2" X 1 3/4"
- 3 NARROW SHELF, ROLLING ISLAND , 3/4" X 6 3/4" X 24"
- 1 TOP, WIDE SHELF, ROLLING ISLAND , 3/4" X 22 1/2" X 22 1/2"
- 2 BOTTOM, WIDE SHELF, ROLLING ISLAND , 3/4" X 22 1/2" X 10 7/8"
- 1 VERTICAL DIVIDER, WIDE SHELF, ROLLING ISLAND , 3/4" X 22 1/2" X 16 3/4"
- 4 RAIL, WIDE SHELF, ROLLING ISLAND , 3/4" X 1 1/4" X 22 1/2"
- 2 DRAWER SIDES, ROLLING ISLAND , 3/4" X 24" X 22 1/2"
- 4 STILE, DRAWER, ROLLING ISLAND , 3/4" X 2" X 29 27/32"
- 4 RAIL, DRAWER, ROLLING ISLAND , 3/4" X 2" X 10 1/2"
- 2 PANEL, DRAWER, ROLLING ISLAND , 1/4" X 26 11/16" X 10 3/8"
- 1 BOTTOM, DRAWER, ROLLING ISLAND , 1/2" X 23" X 12 1/2"

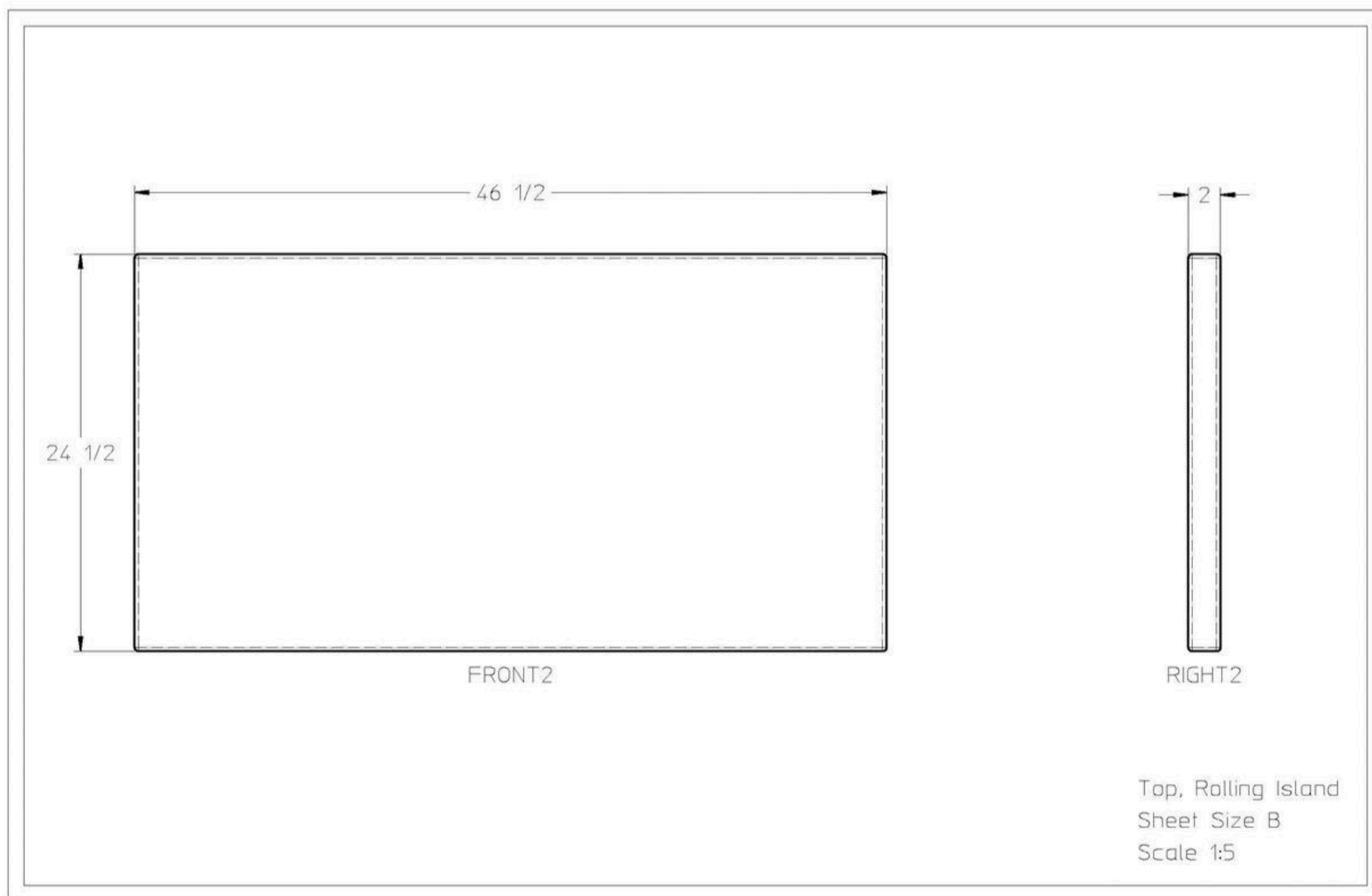

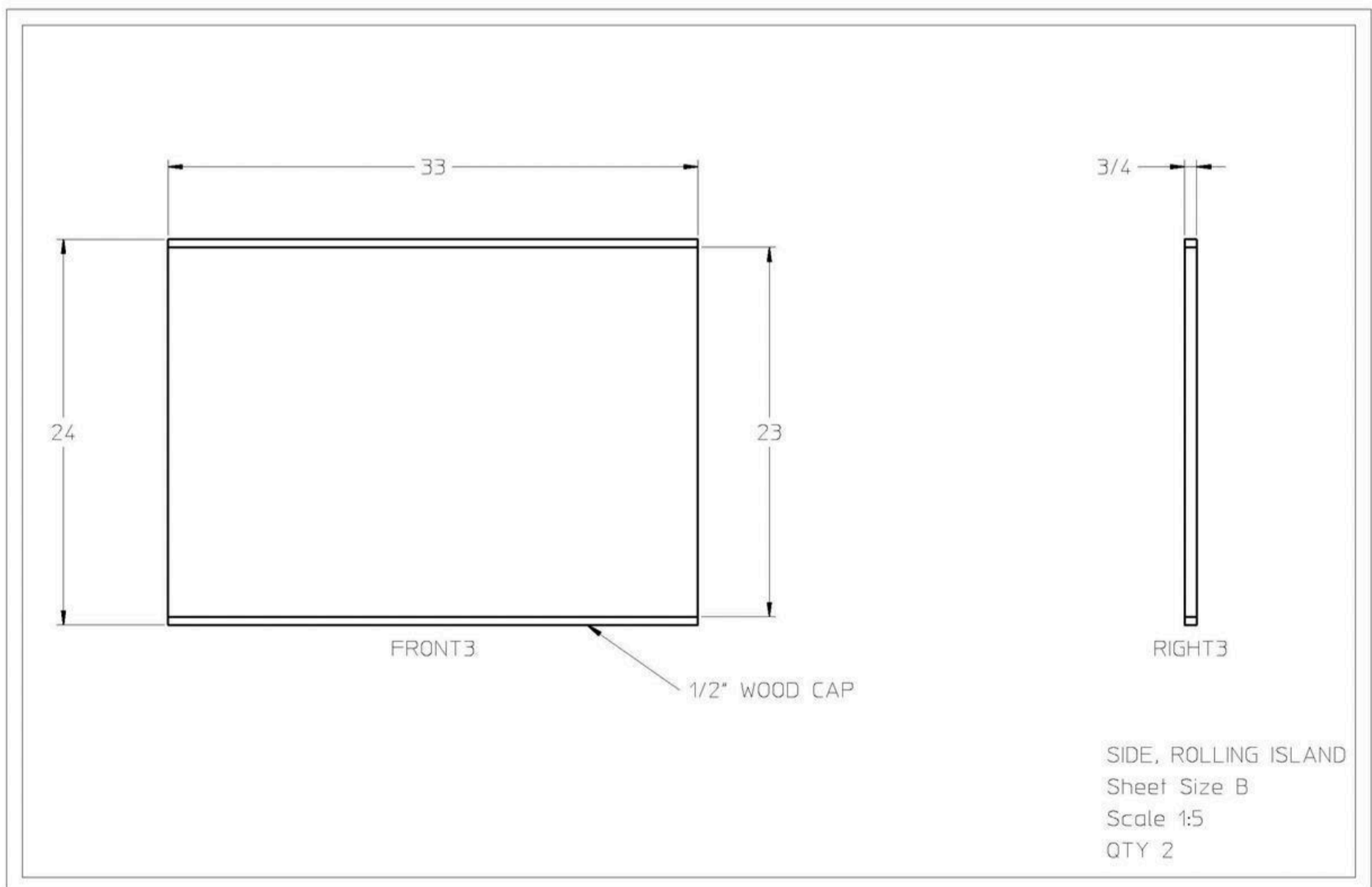
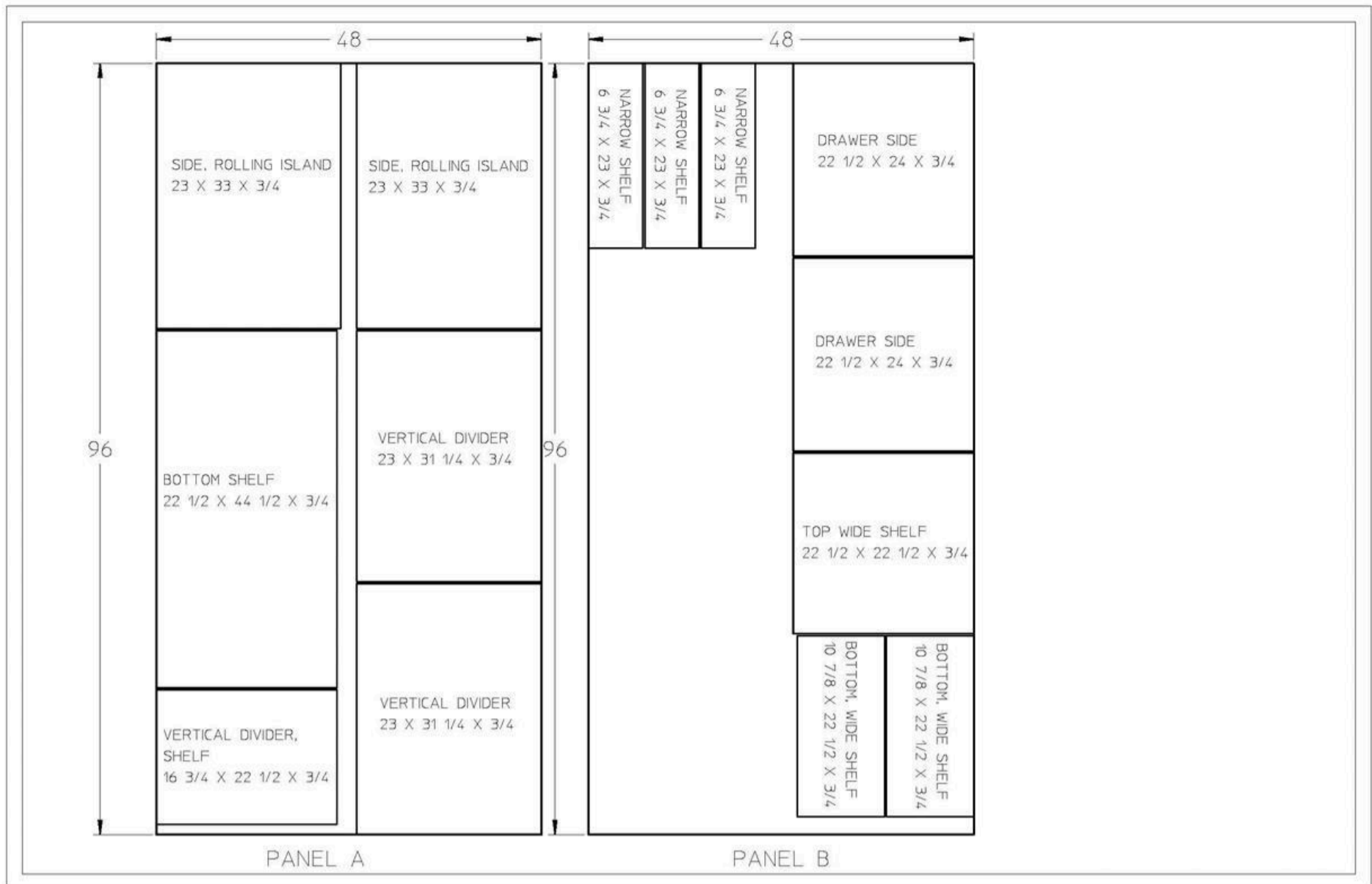

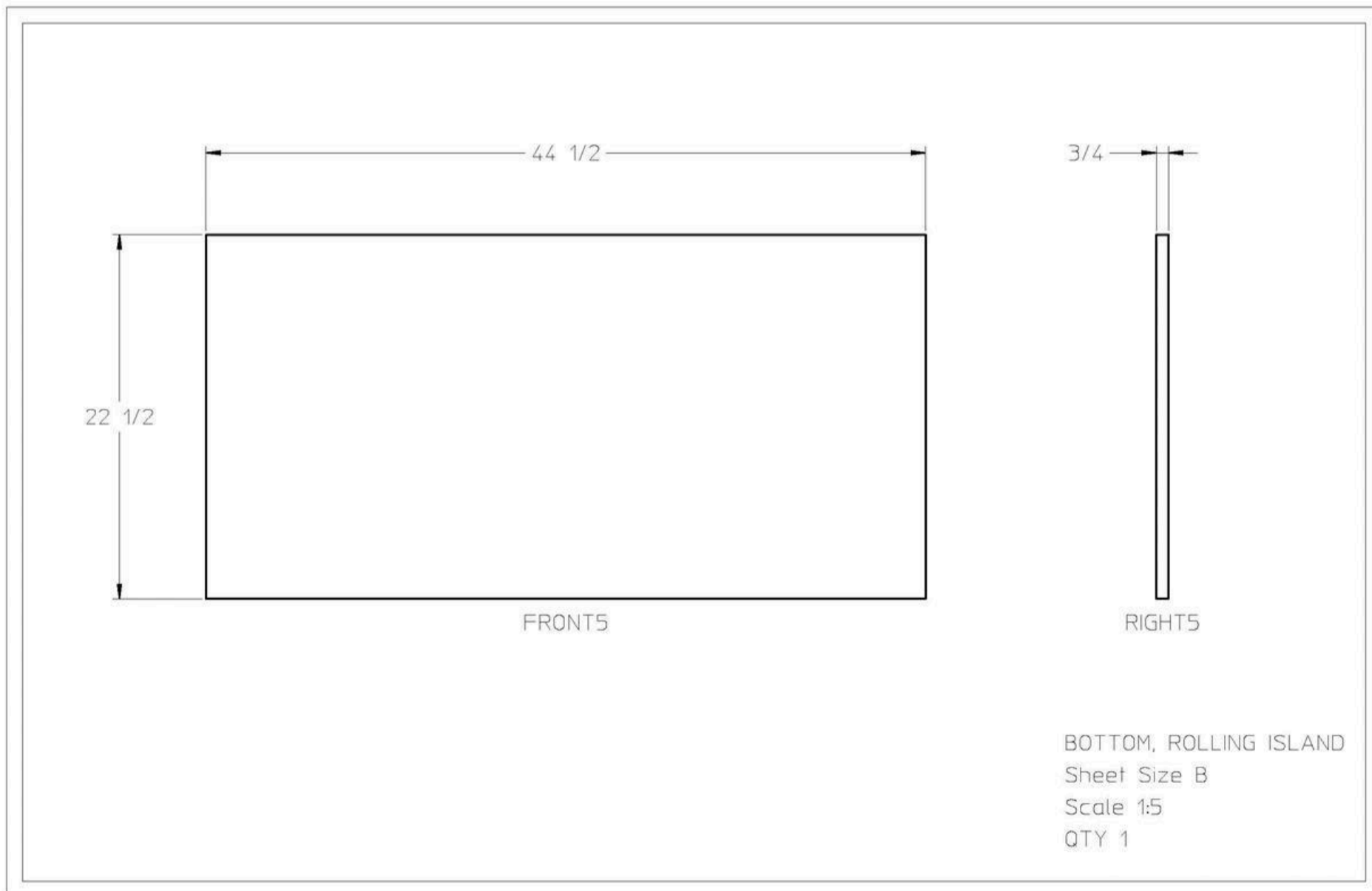
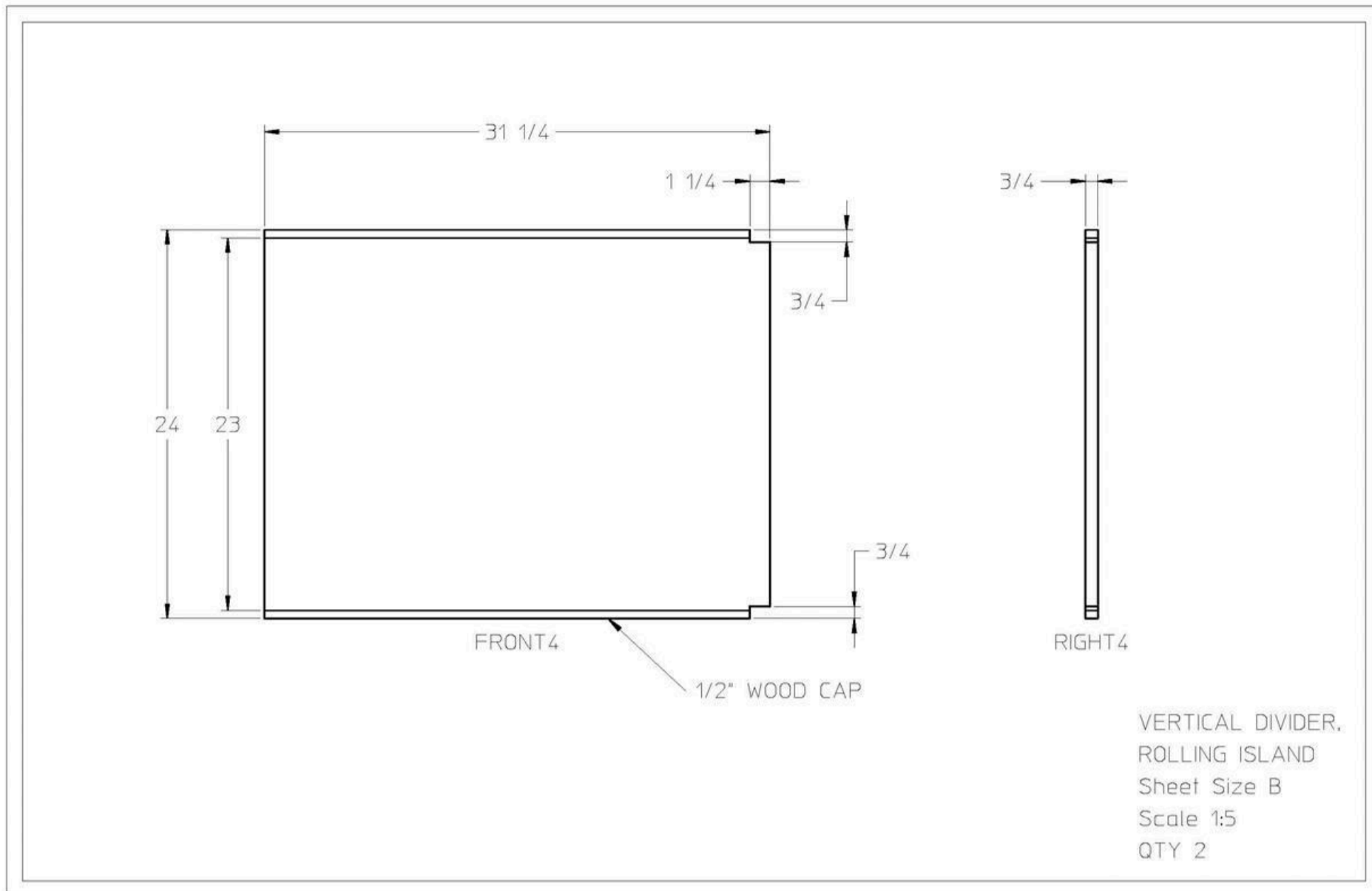

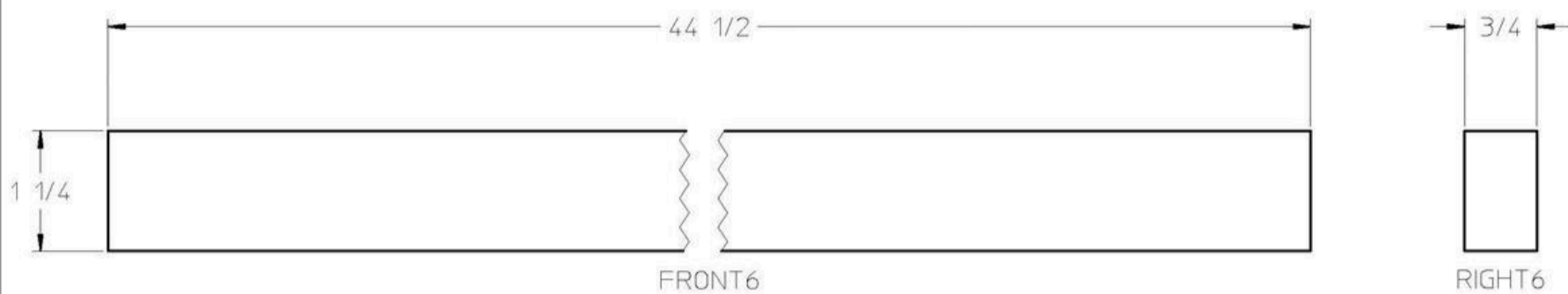

TOP RAIL, ROLLING
ISLAND
Sheet Size B
Scale 1:1
QTY 2

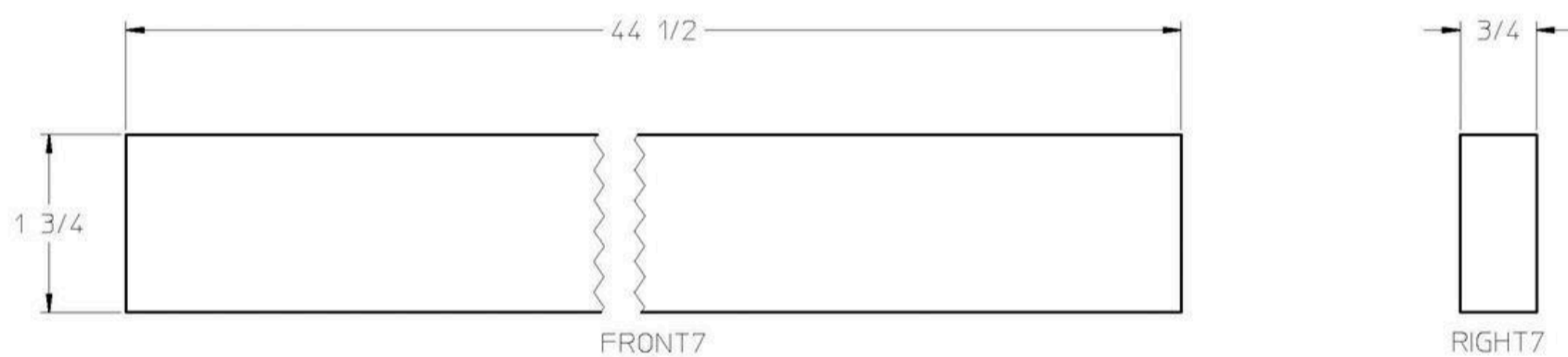

BOTTOM RAIL,
ROLLING ISLAND
Sheet Size B
Scale 1:1
QTY 2

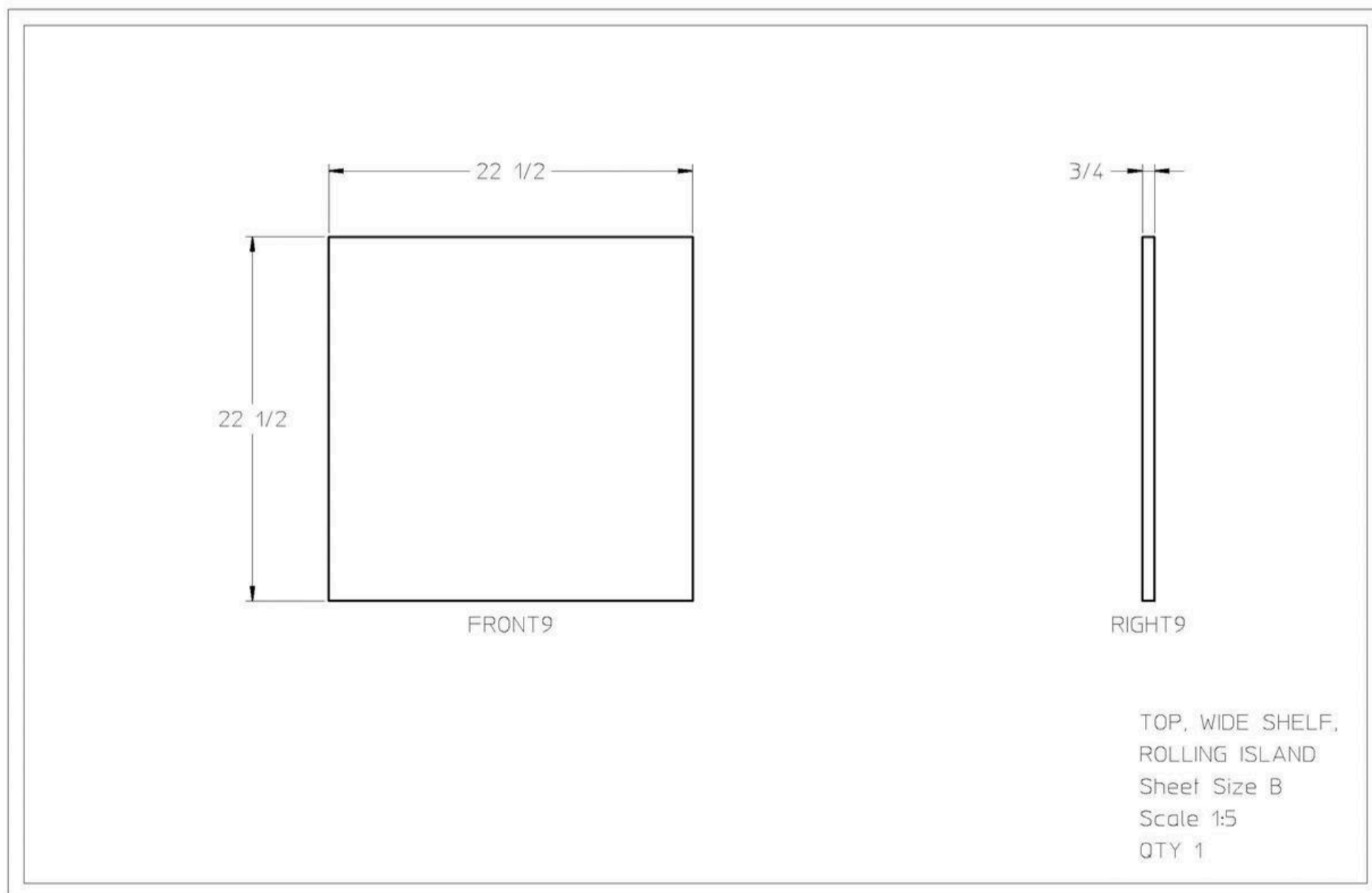
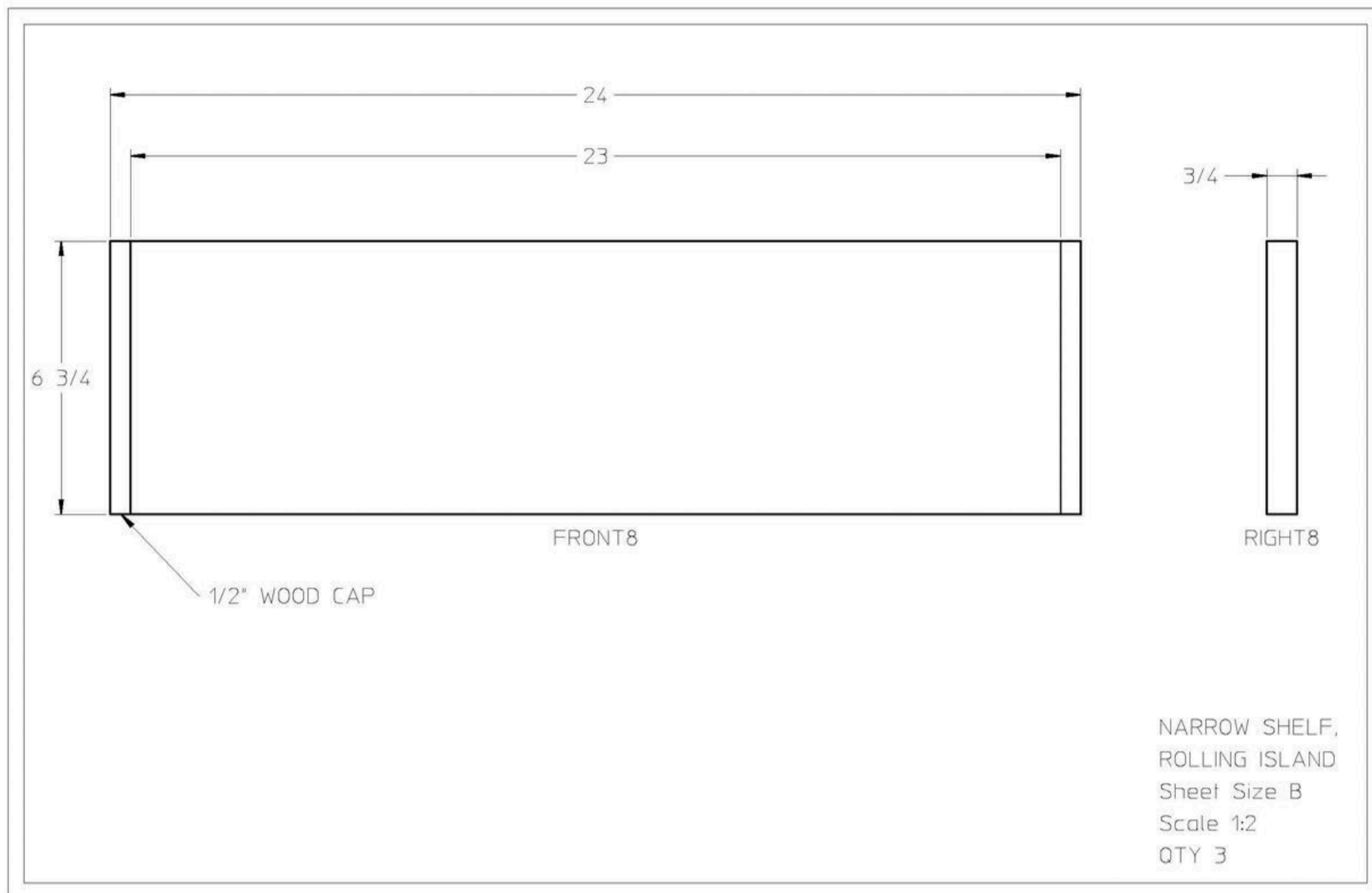

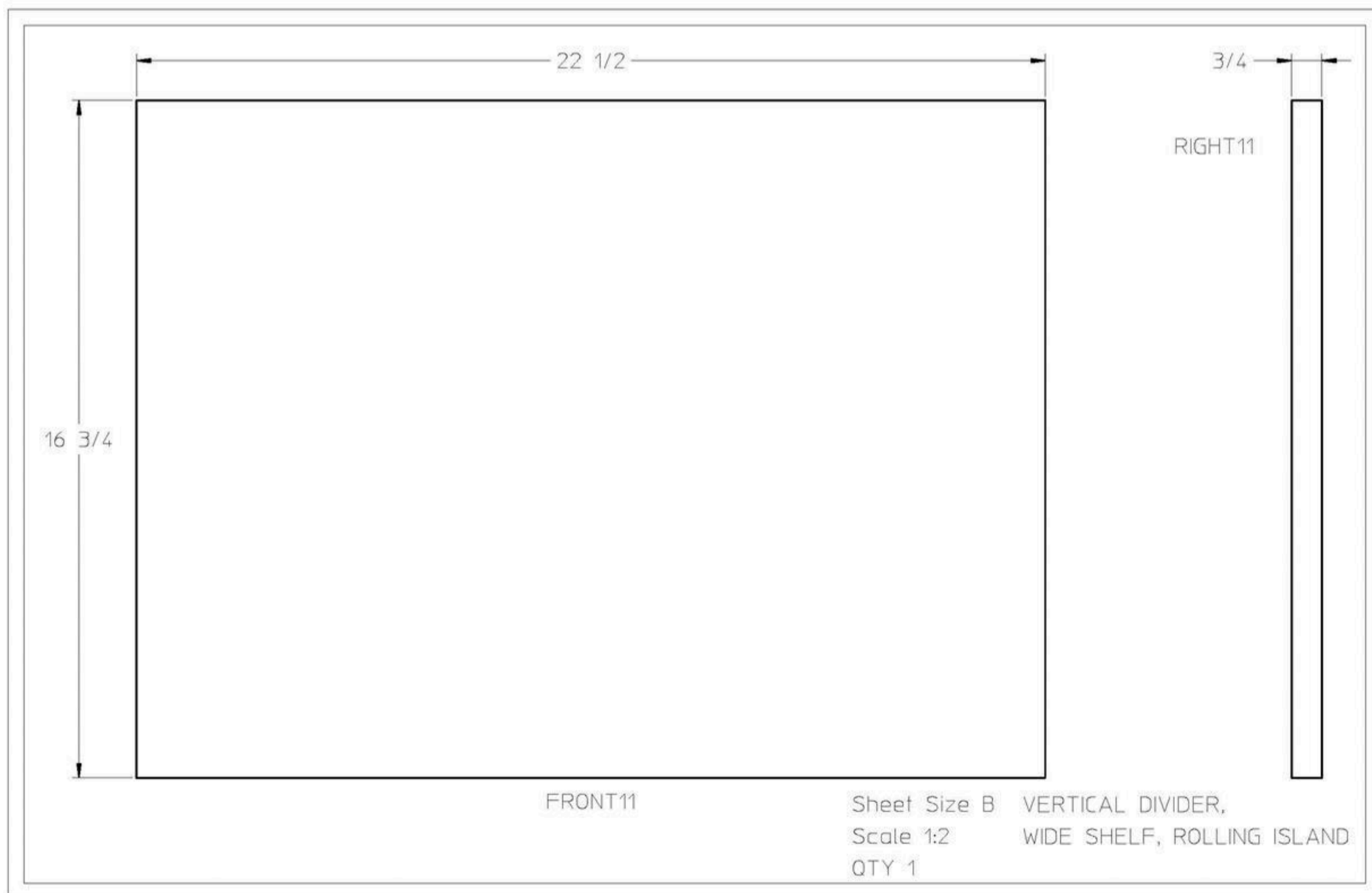
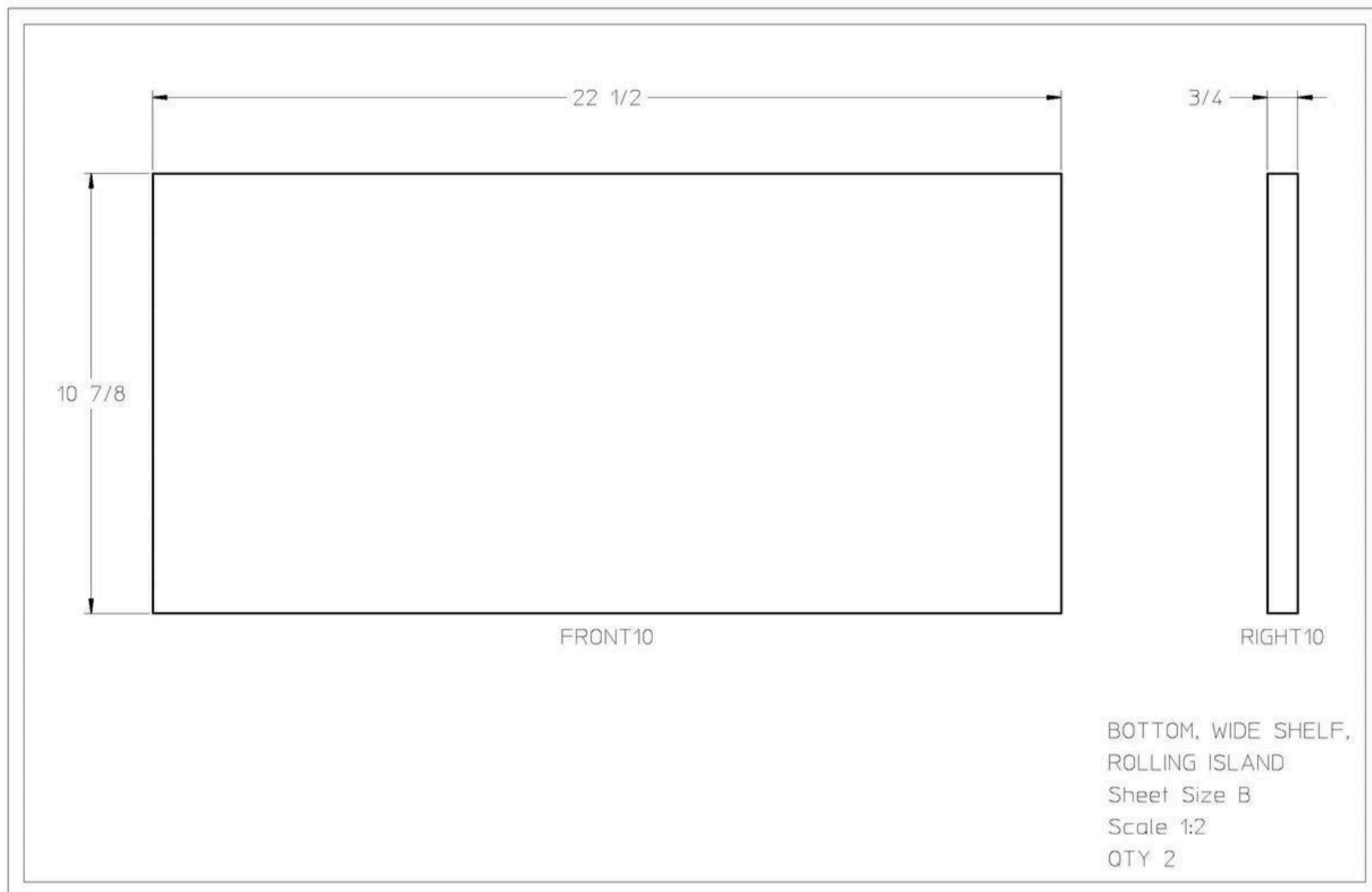

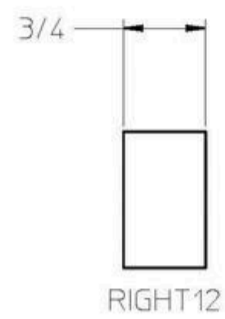
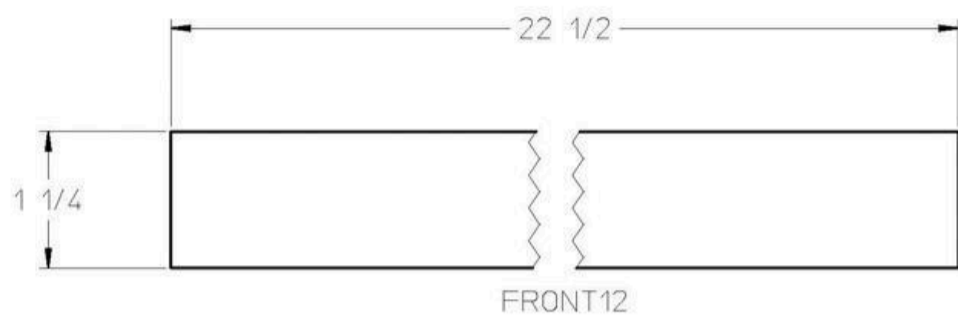

RAIL, WIDE SHELF
ROLLING ISLAND
Sheet Size B
Scale 1:1
QTY 4

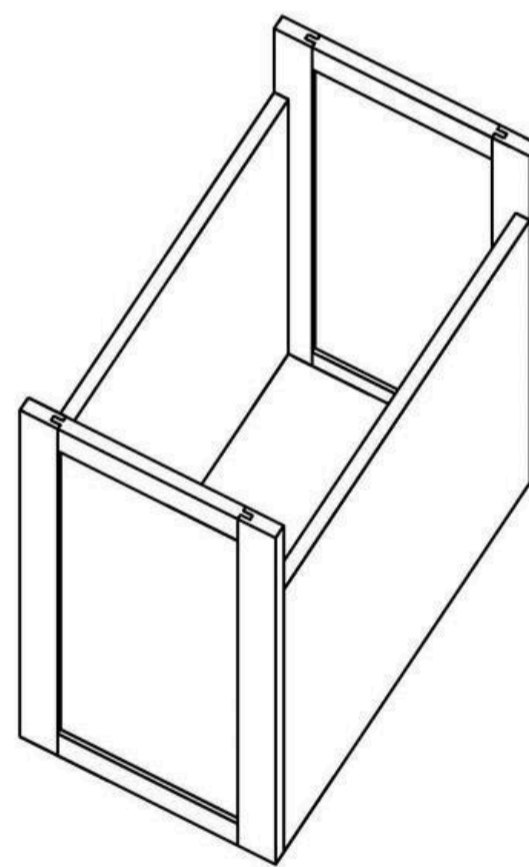
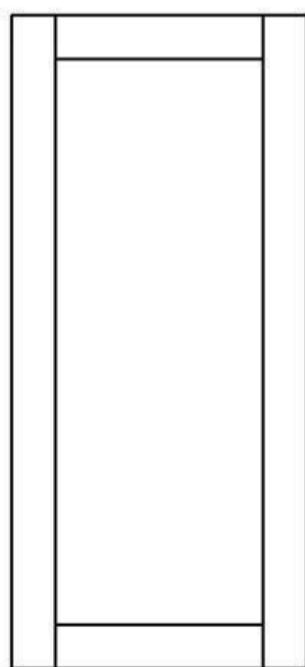
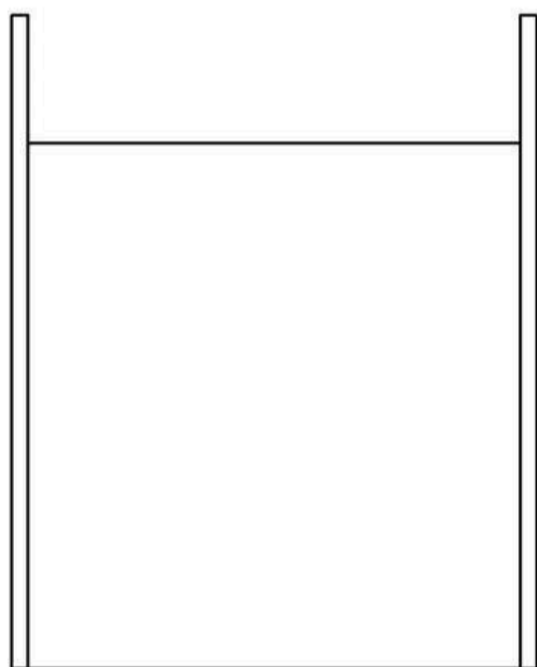

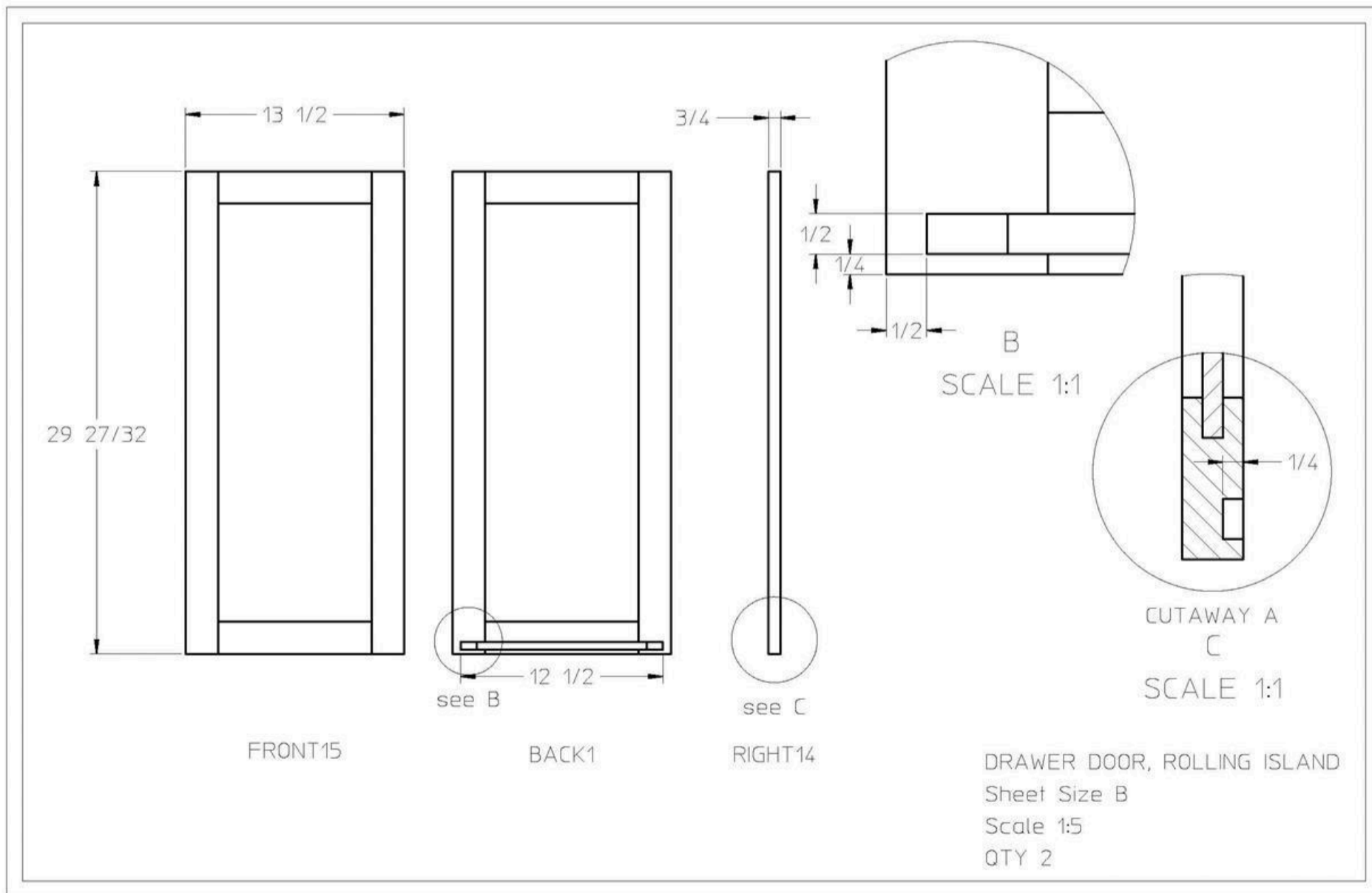
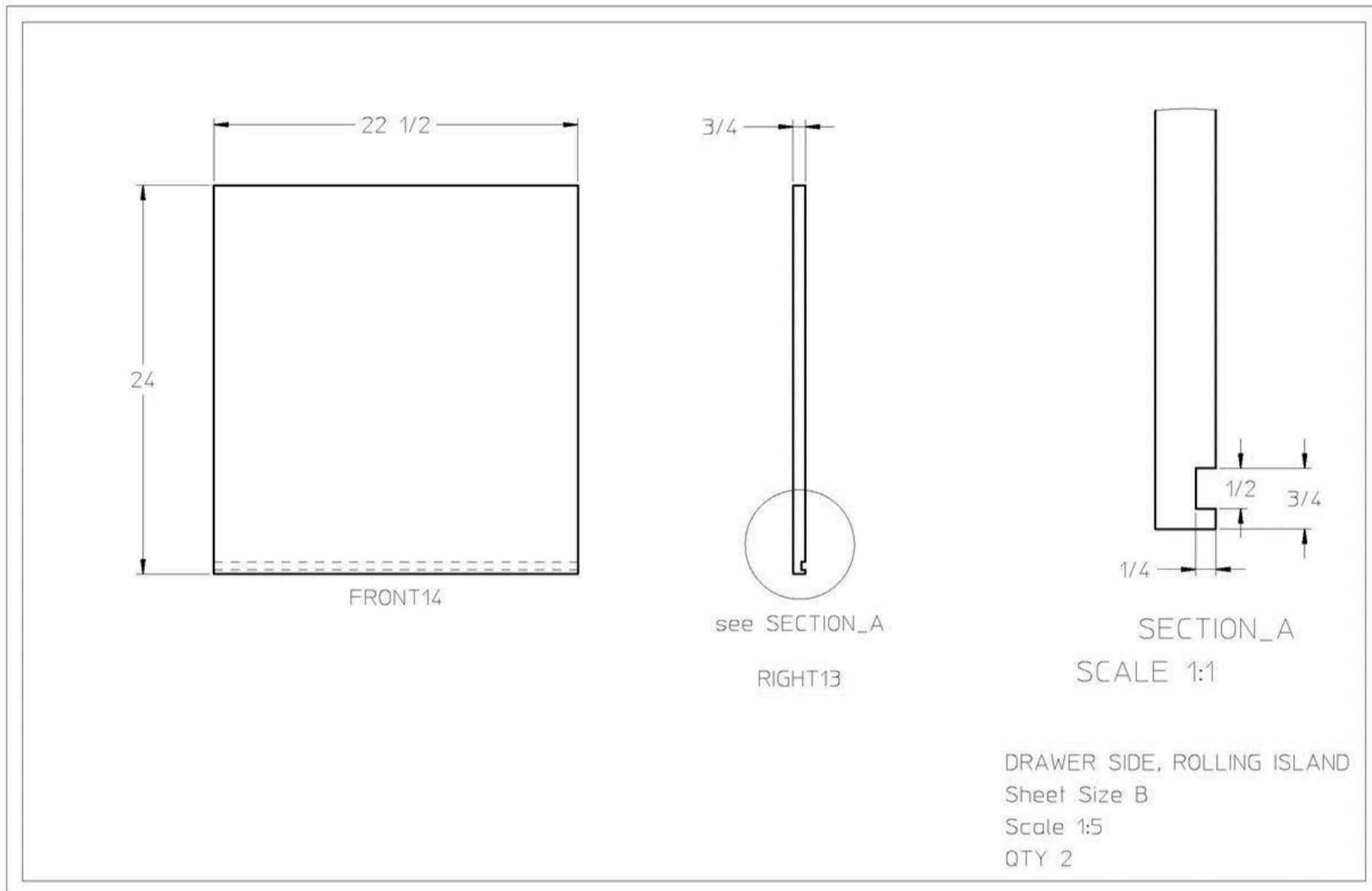

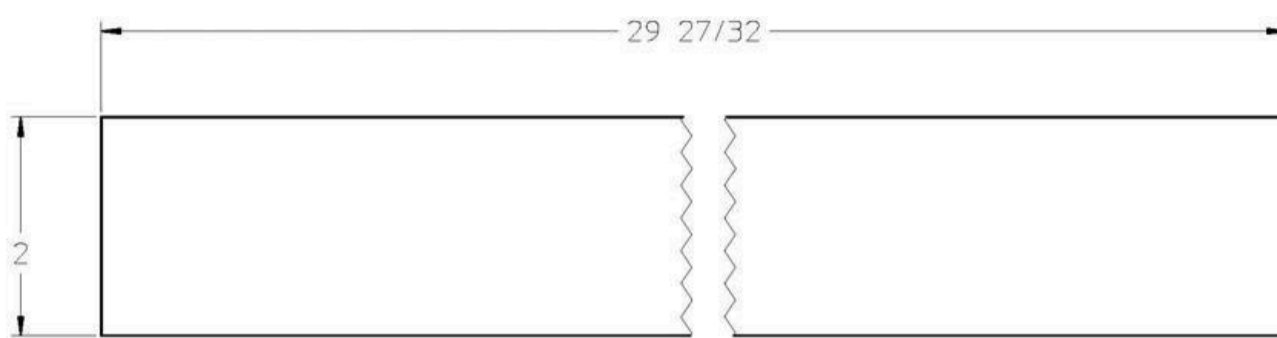

FRONT16

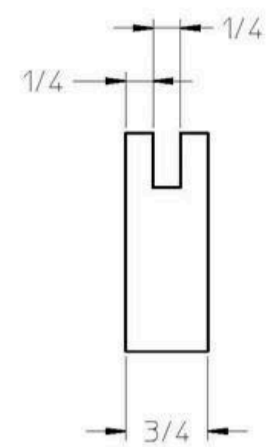

RIGHT15

STILE, DRAWER DOOR,
ROLLING ISLAND
Sheet Size B
Scale 1:1
QTY 4

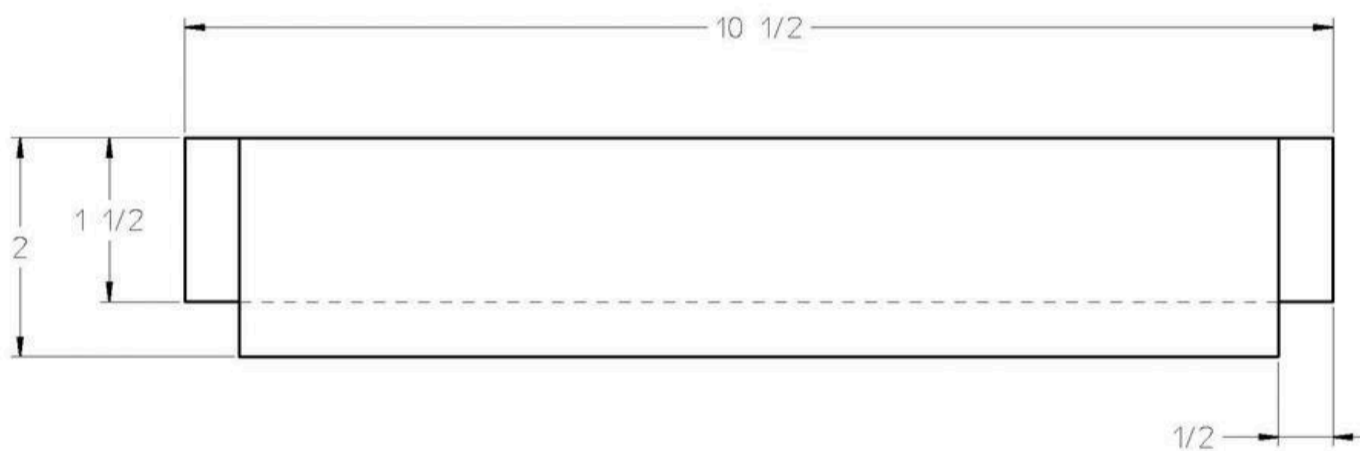

FRONT17



RIGHT16

RAIL, DRAWER DOOR,
ROLLING ISLAND
Sheet Size B
Scale 1:1
QTY 4

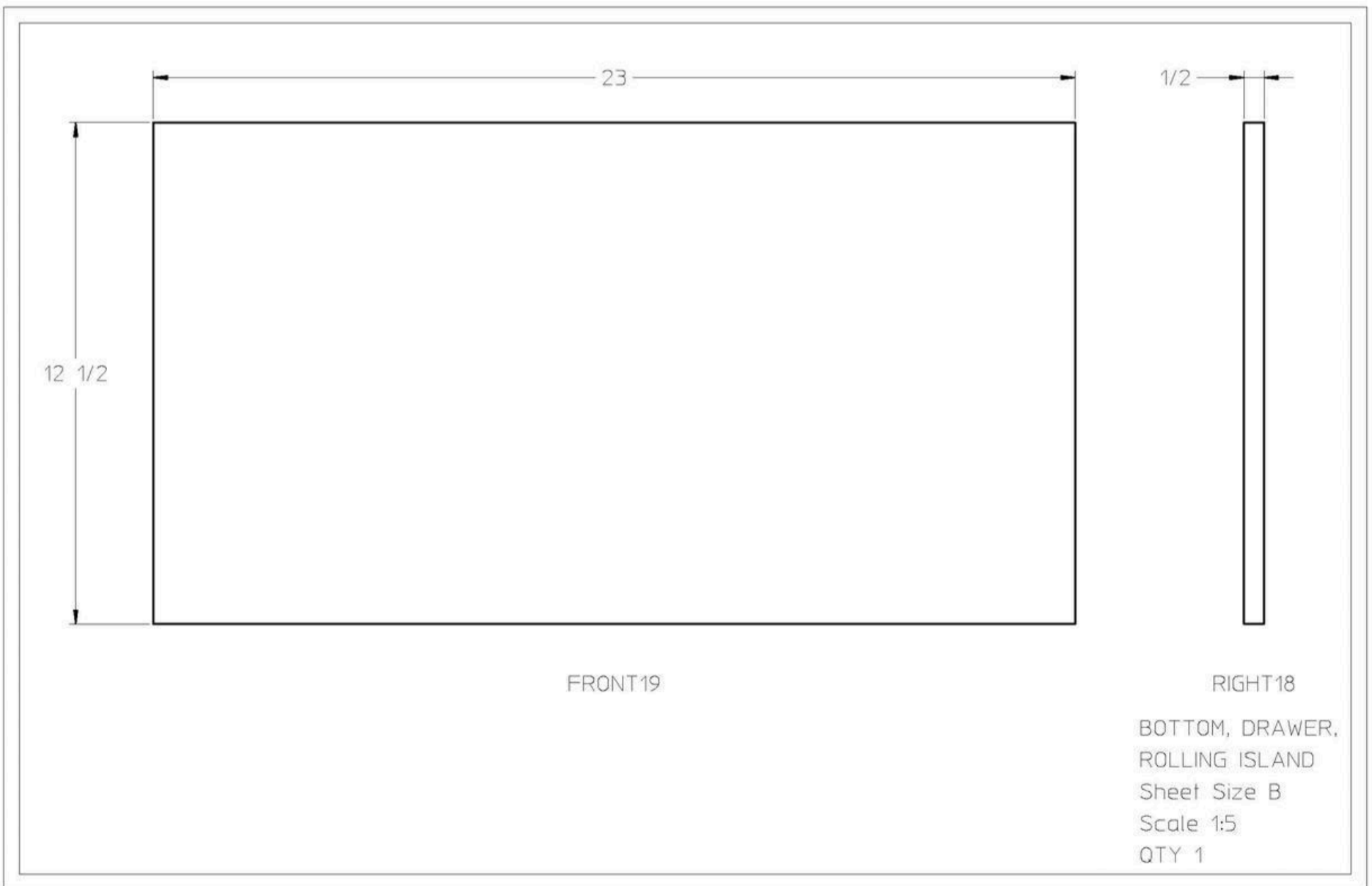

Directions

1

Review plan

Come on over to our blog for the full post and more reveal pics! >> <http://realitydaydream.com/2016/02/custom-diy-rolling-kitchen-island.html>

Take a look at the plans to help map your way through the project. You Can download a PDF of the plans in the EXTRA section

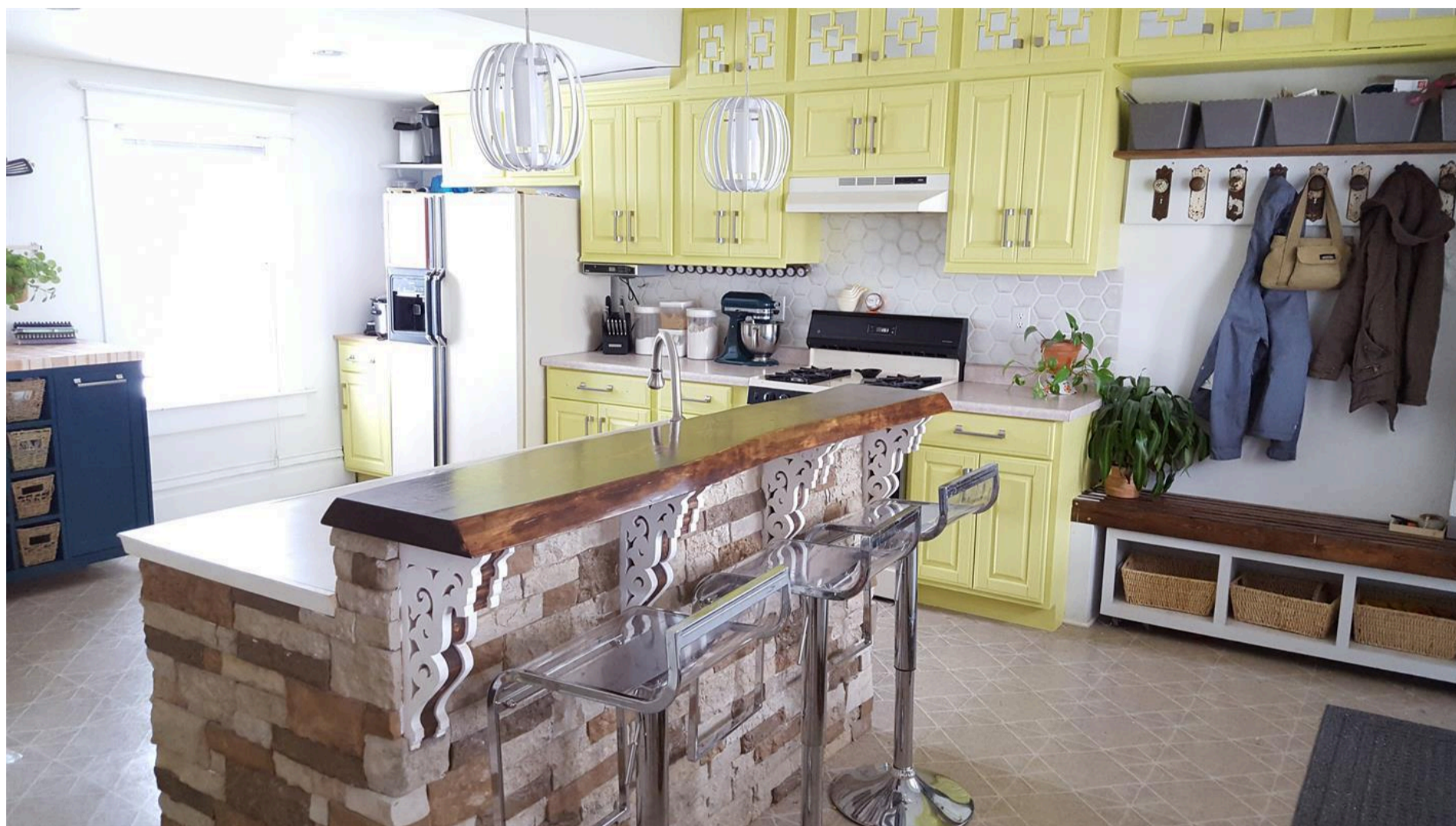

2

Cut sheet goods

Cut the sheet goods, you will notice on the print that we capped most things with a 1/2" of poplar. If you don't want to do this it is fine but you will need to make some adjustments to the cut diagram.



3

Cap plywood

Cut 1/2" Stripes of Poplar and cap required pieces of plywood.



4

Flush caps

Using a flushing bit on a router, flush trim all the poplar caps.



5

Layout drilling locations

Using a "T" square, mark locations for drilling per drilling instructions in the prints.

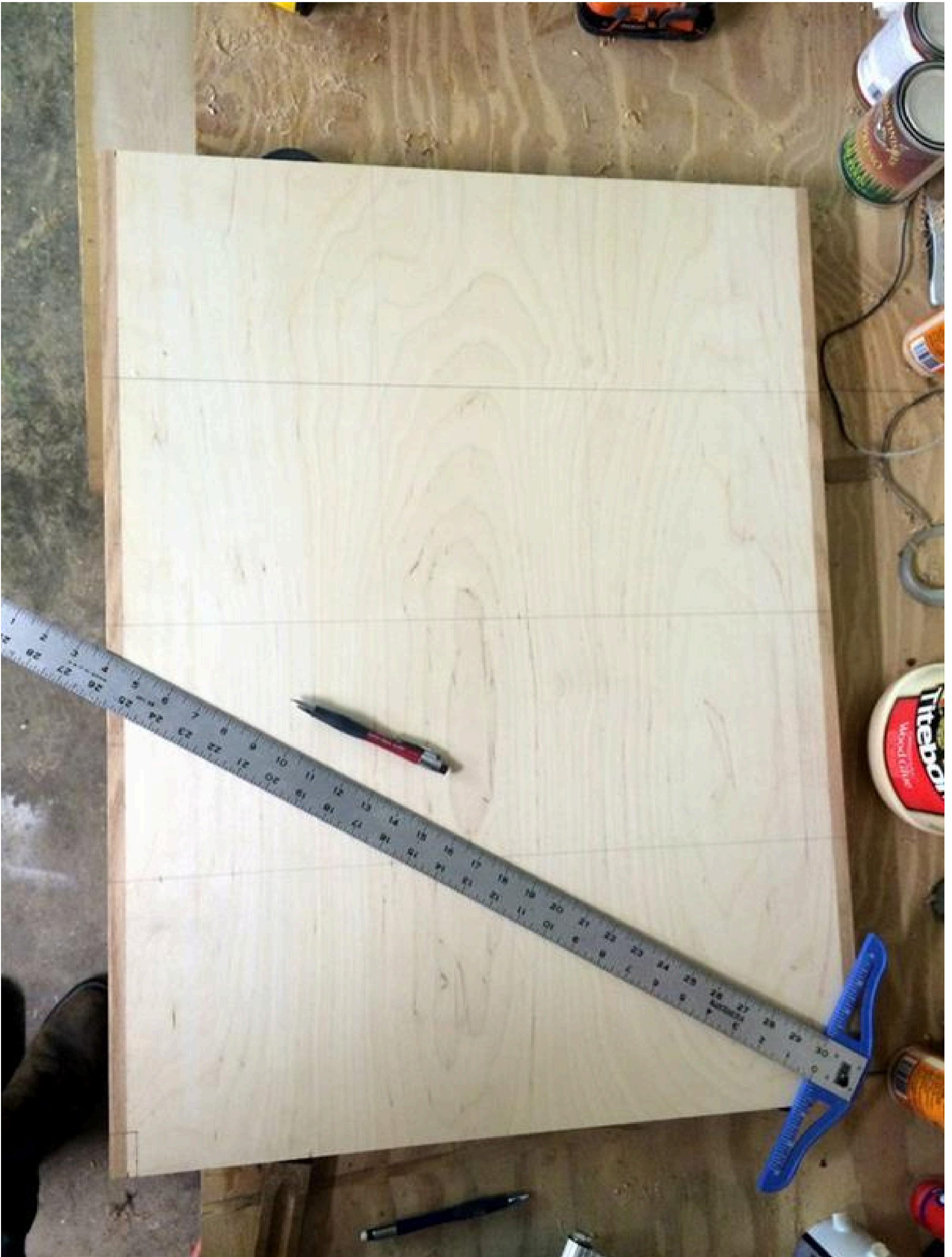

6

Drill through holes

Drill the through holes and counterbores per prints.



7

Drill pocket holes

We use a Kreg Foreman to drill the required pocket holes.



8

Cut fronts for wide shelves

Cut the four rails for the wide shelves. Then route the bottom edges with a 1/4" round over bit.

9

Attach the shelf fronts

Glue and screw the fronts onto the shelves. You may need to clean up the ends with a table saw.



10

Sand

We chose to sand and prime/paint prior to assembly. If you have helpers this is a great project for them.



11

layout

Mark off where all the boards go using a "T" square and measuring out $\frac{3}{8}$ " both ways from the drilling locations you marked out earlier.

12

Tape

Tape off where the boards will be going.

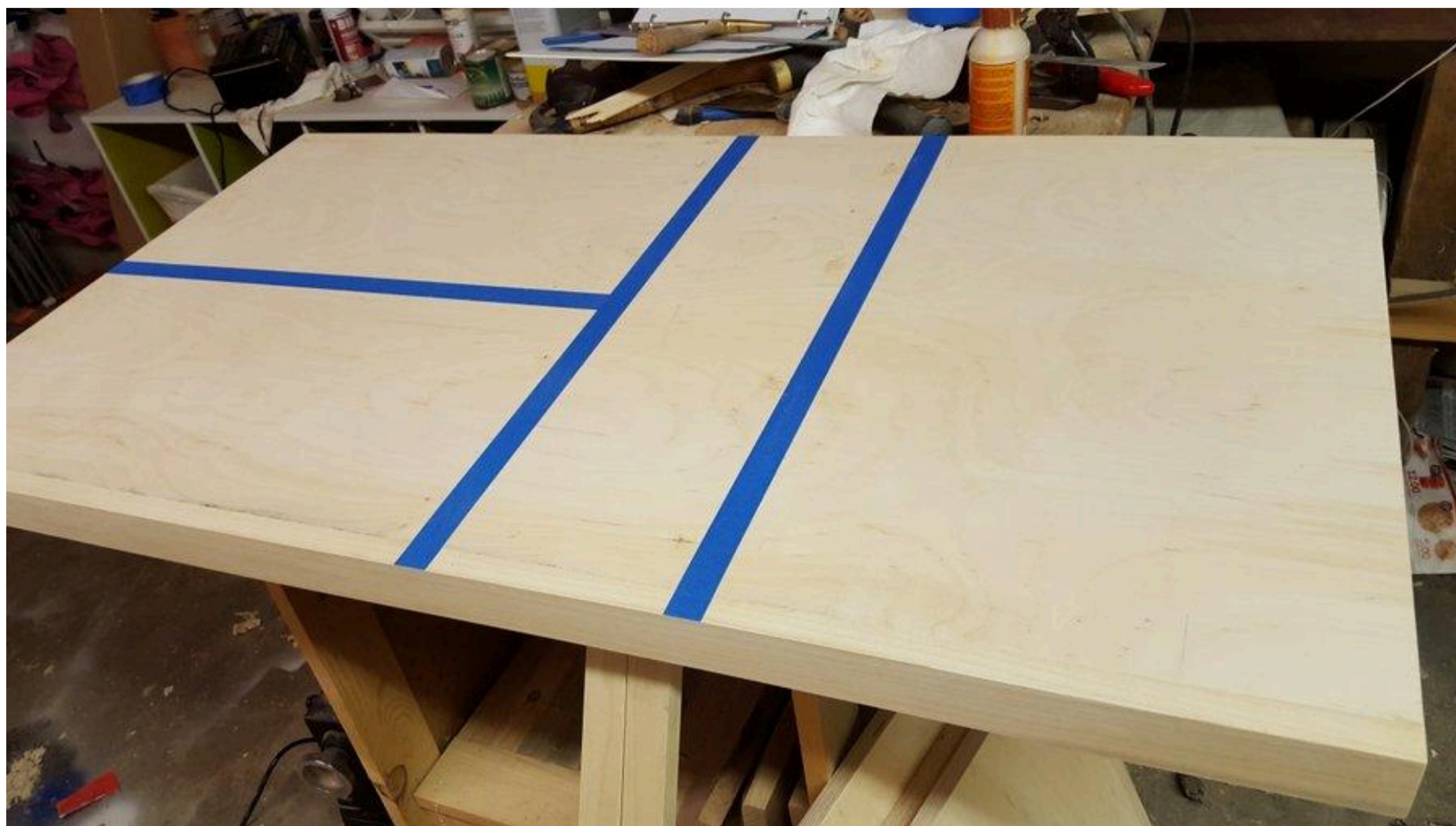

13

Cut Notches

Cut notches per the print out of the two vertical dividers.



14

Stiles and Rails

Cut the stiles and rails out of poplar.

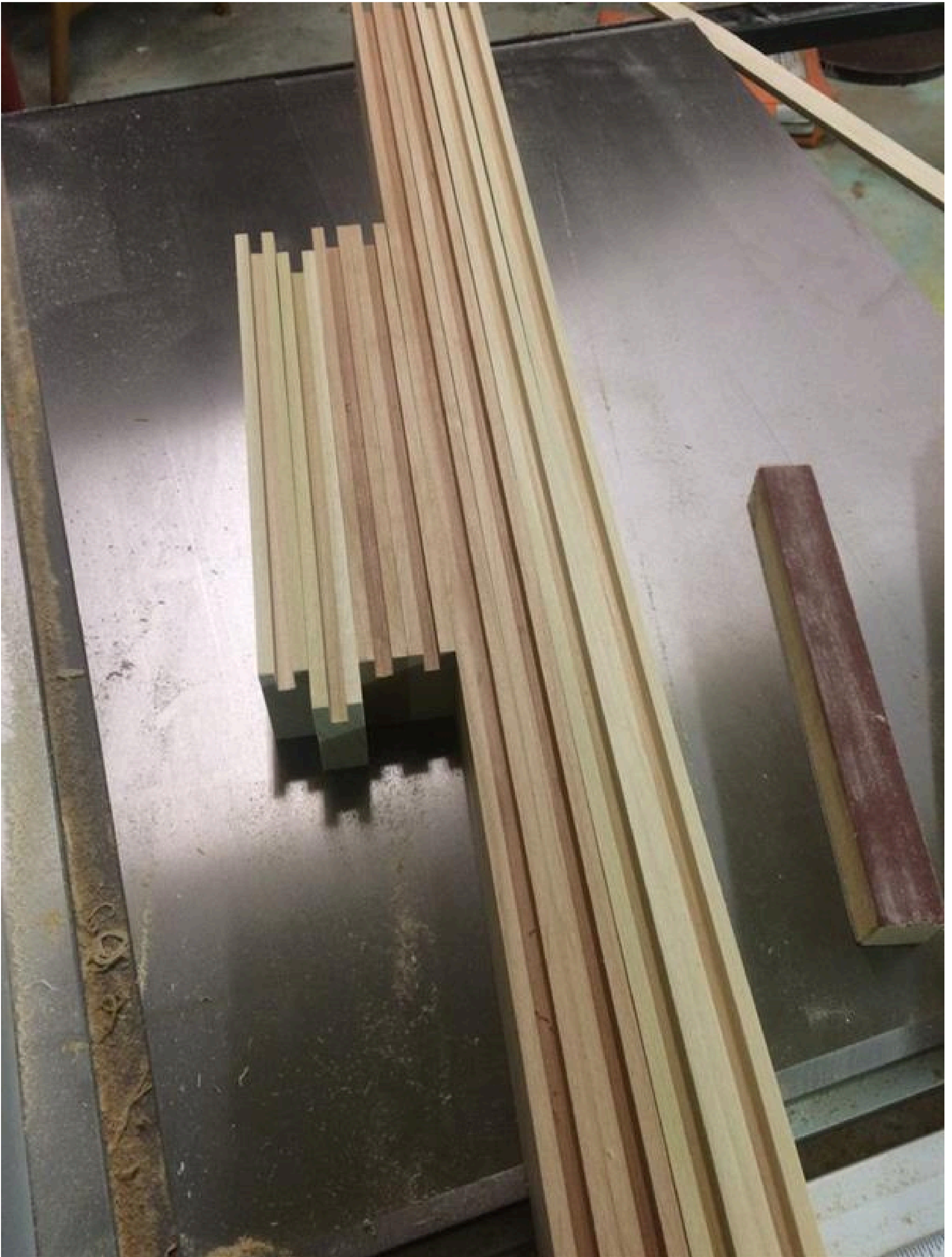

15

Stub Tenon

Cut the Stub tenons with a Precision miter gauge.



16

Glue drawer fronts

Glue stub tenons and clamp drawer fronts.



17

Prime

Prime parts



18

Paint smaller areas

paint smaller, hard to reach areas like the narrow shelves.

19

Cut the Upper and Lower Rails

Cut the Upper and lower Rolling island rails.

20

Attach Lower Rail

Attach the lower rails to the bottom shelf. If either of the rails overhang you will want to trim them up on the table saw.

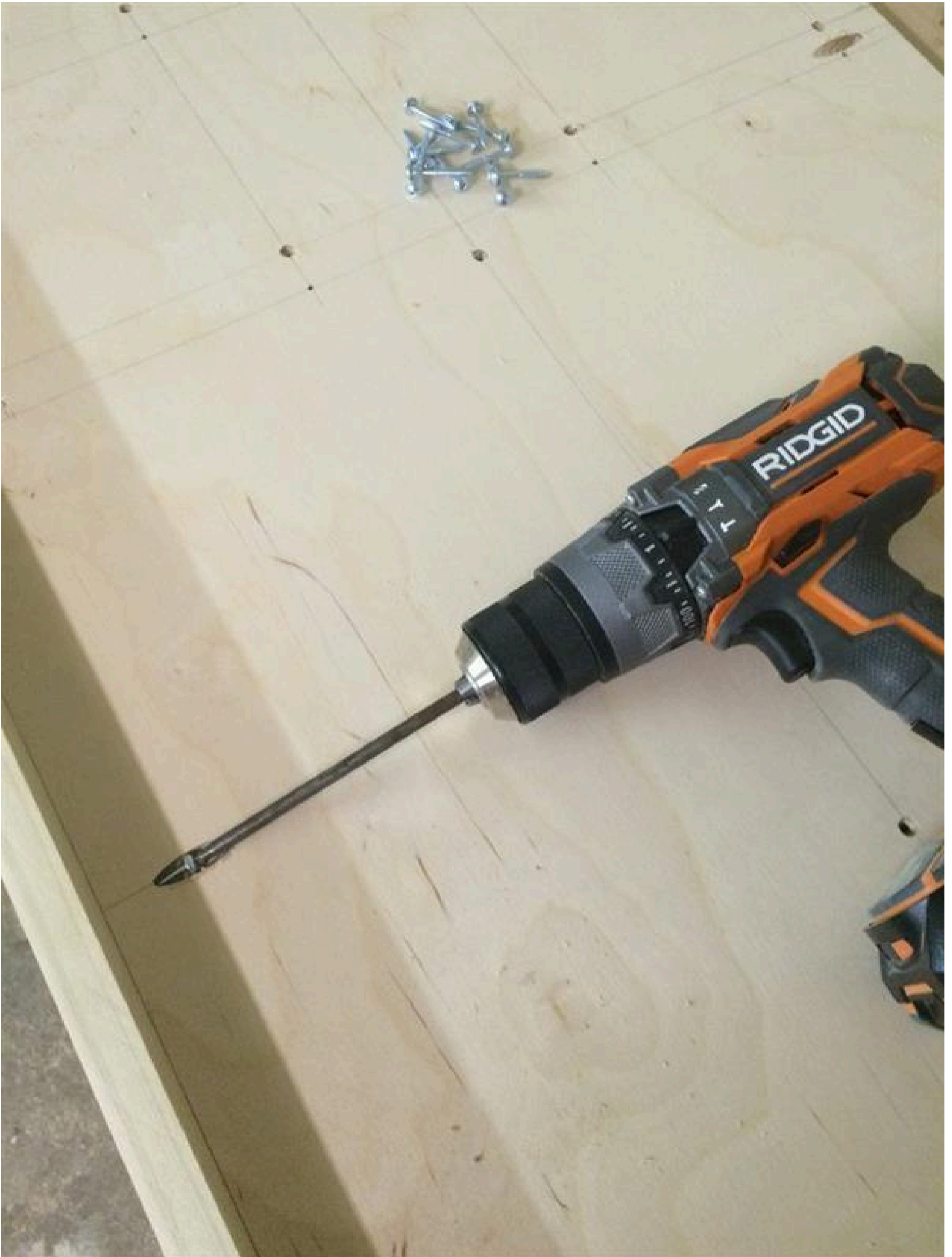

21

Assemble

Remove the tape, and start to assemble.

we started with the narrow shelves. Assembling them to the left vertical divider.

Then we attached the left side the the bottom of the rolling cabinet.

Next we attached the wide shelves and the vertical divider between them.



22

Assemble

Then attach the right side and the two top rails.



23**Paint**

Paints

**24****Drawer**

Cut a 1/2" groove in the drawer sides and drawer fronts.

25**Assemble drawer**

Assemble drawer. We used a teflon tape on the bottom of the drawer to reduce friction.

26**Add Butcher Block Top**

The choices for tops on this rolling island are virtually endless. We will be posting about ours sometime in the future at www.thesawdustmaker.com.

27**Wheels**

using a 1" thick piece of wood as a spacer attach the 4 wheels to make the cart mobile.