

# DIY Outdoor Coffee Table

By **Anika's DIY Life**

Difficulty

Easy

A simple outdoor coffee table to match any patio set for under \$15. Overall dimensions – 35" x 22" and 17 3/4" high.



# Tools

## Kreg Tools



## Other Tools

Miter Saw

Drill (cordless)

Sander

# Materials

## Wood Products

**3** Board , 2x2 , 96"

**4** Board , 1x3 , 96"

## Hardware & Supplies

**50** 2 1/2" Blue Kreg Screws Coarse

**25** 2" Wood Screws

**1** Outdoor Primer

**1** Outdoor Paint

**1** Wood Putty

# Cut List & Parts

- 4 Legs , 17" X 2" X 2"
- 4 Short Aprons And Leg Supports , 17" X 2" X 2"
- 2 Top Supports , 17" X 2" X 2"
- 2 Long Aprons , 29" X 2" X 2"
- 1 Bottom Long Support , 29" X 2" X 2"
- 8 Top Slats , 35" X 1" X 3"

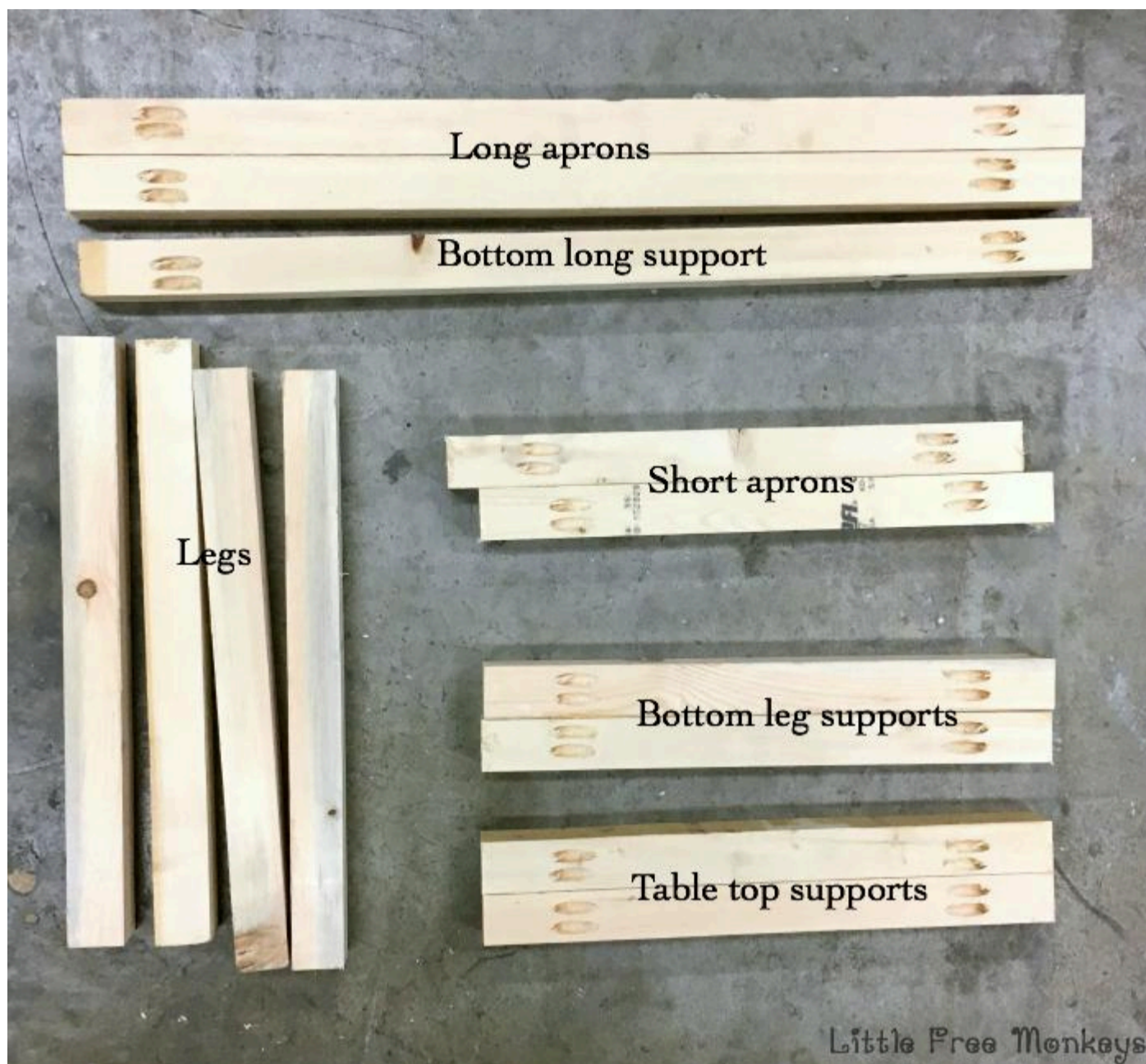

# Directions

1

## Make side frames

Create the 2 side frames using the Legs, short apron and the bottom leg supports. The bottom leg support are 3" from the edge of the leg.

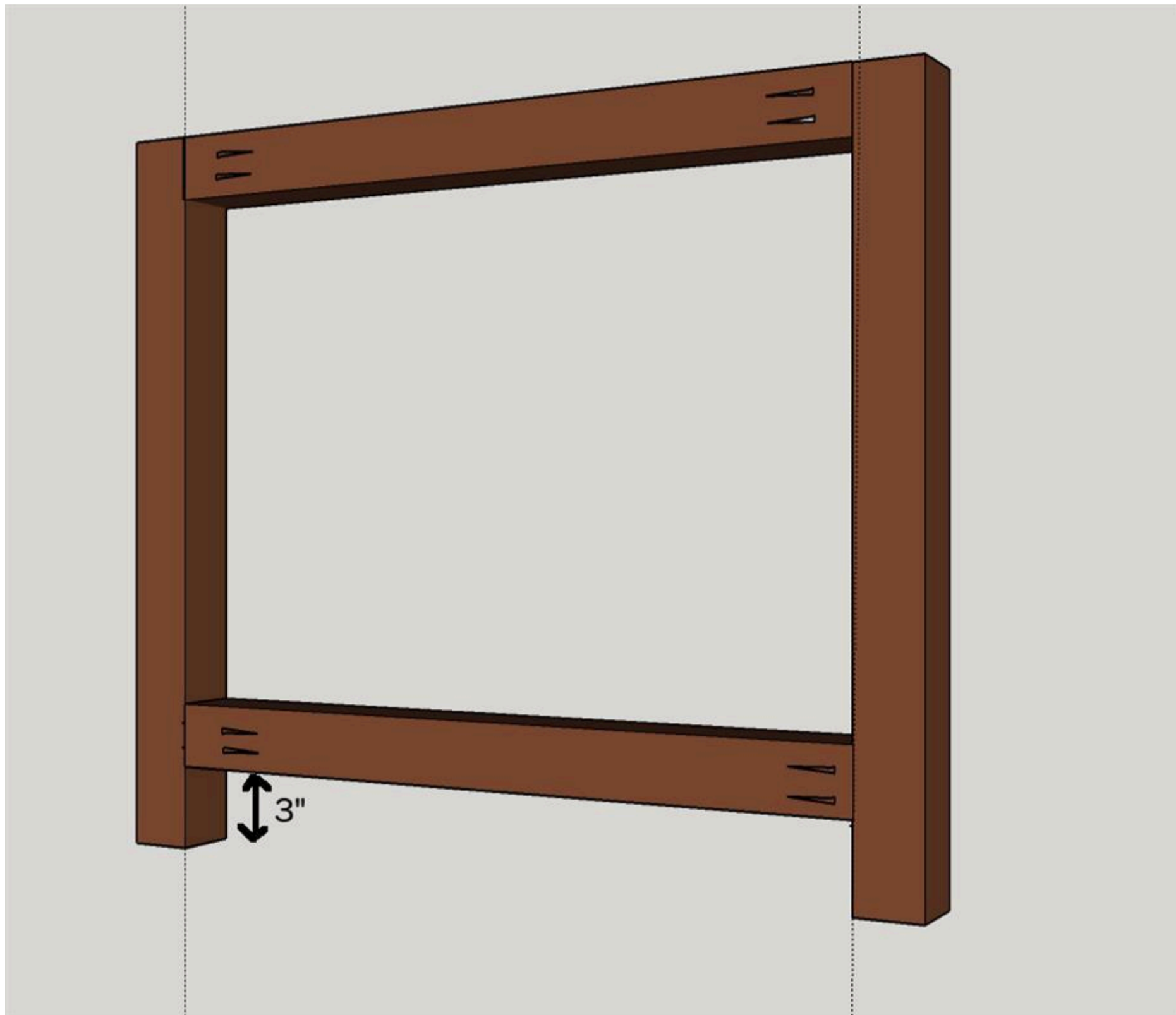

2

## attach long aprons

Attach the long aprons and create the table frame.



3

### Attach bottom support

Attach the bottom long support. This is 7.75" from the side of the leg.

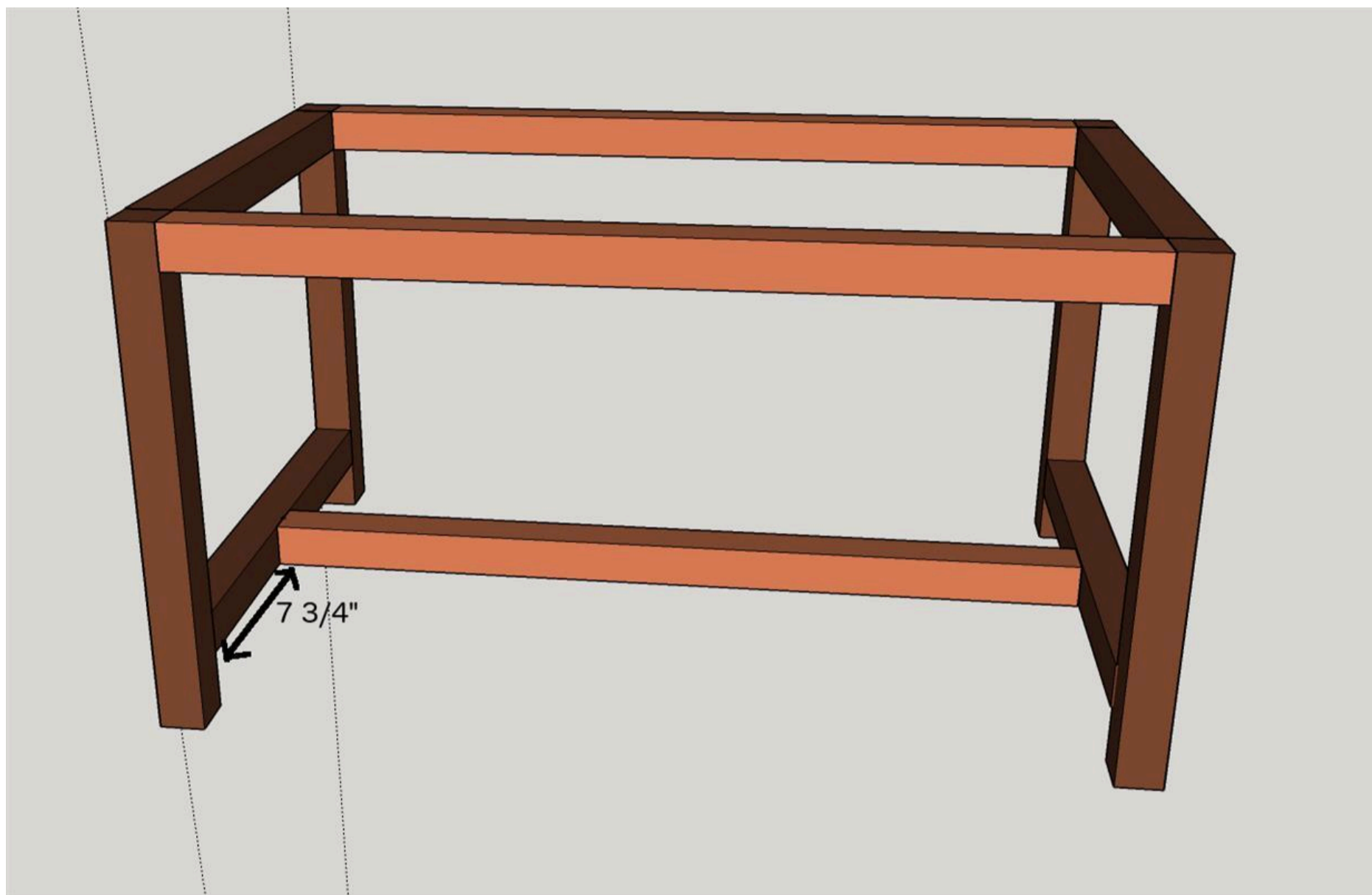

4

### Attach table supports

Attach the table top supports. I attached these 11" from each end.

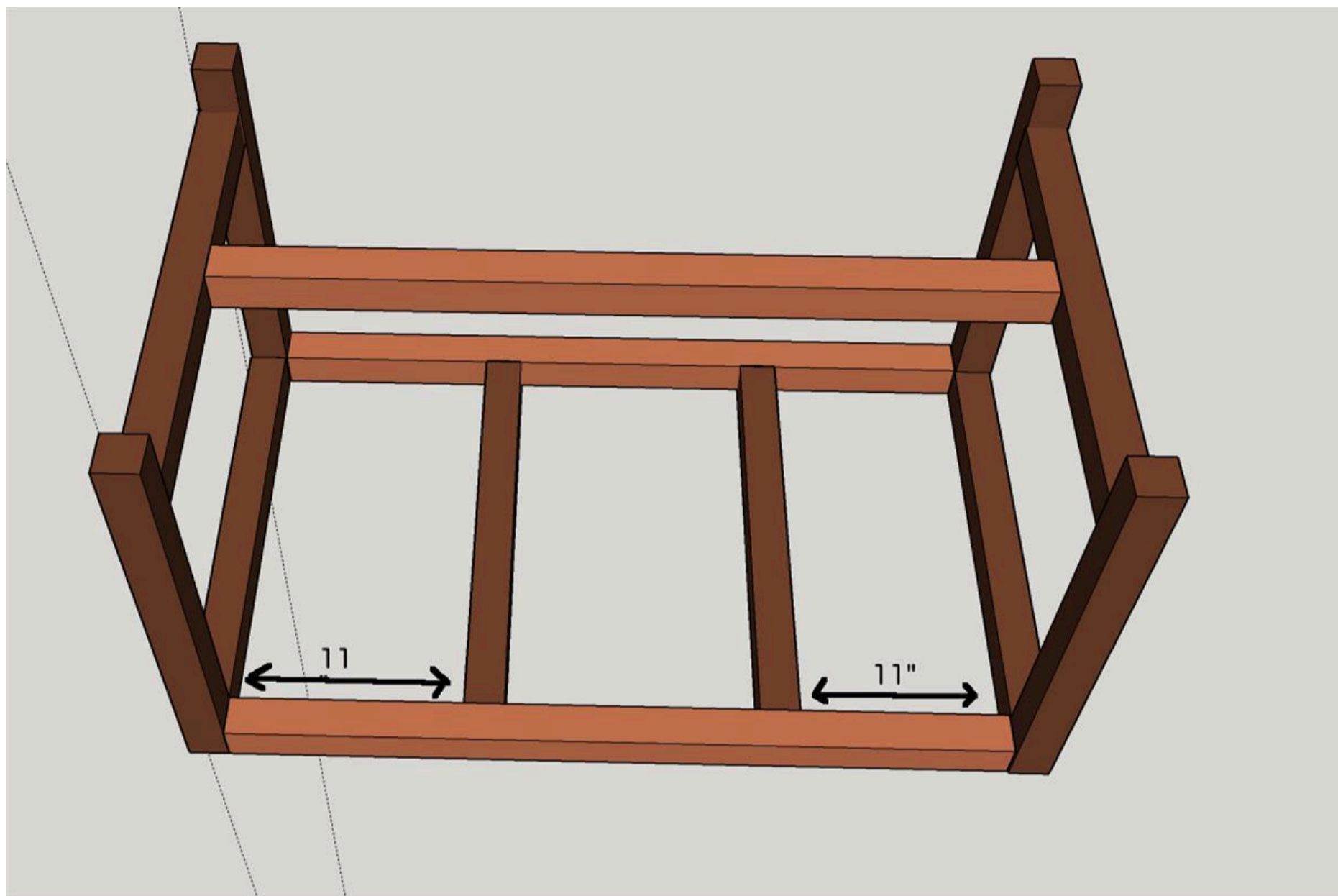

5

### Assemble table top slats

Assemble the table top slats onto the frame. I used 1.5" overhang on both sides of the slats. The first slat was attached flush on the inside edge of the long apron giving a 1" overhang in the front of the table. I used a yard stick which was about 1/4" thick as a spacer between the slats.

